

SECTION **BRC**

BRAKE CONTROL SYSTEM

A
B
C
D
E

CONTENTS

VDC/TCS/ABS		BRC
BASIC INSPECTION	Component Parts Location	20
DIAGNOSIS AND REPAIR WORK FLOW	Component Description	22
Work Flow	EBD	23
Diagnostic Work Sheet	System Diagram	23
INSPECTION AND ADJUSTMENT	System Description	23
ADDITIONAL SERVICE WHEN REPLACING CONTROL UNIT	Component Parts Location	24
ADDITIONAL SERVICE WHEN REPLACING CONTROL UNIT : Description	Component Description	26
ADDITIONAL SERVICE WHEN REPLACING CONTROL UNIT : Special Repair Requirement	DIAGNOSIS SYSTEM [ABS ACTUATOR AND ELECTRIC UNIT (CONTROL UNIT)]	27
ADJUSTMENT OF STEERING ANGLE SENSOR NEUTRAL POSITION	CONSULT-III Function	27
ADJUSTMENT OF STEERING ANGLE SENSOR NEUTRAL POSITION : Description	DTC/CIRCUIT DIAGNOSIS	32
ADJUSTMENT OF STEERING ANGLE SENSOR NEUTRAL POSITION : Special Repair Requirement	C1101, C1102, C1103, C1104 WHEEL SENSOR	32
SYSTEM DESCRIPTION	Description	32
VDC	DTC Logic	32
System Diagram	Diagnosis Procedure	32
System Description	Special Repair Requirement	34
Component Parts Location	C1105, C1106, C1107, C1108 WHEEL SENSOR	35
Component Description	Description	35
TCS	DTC Logic	35
System Diagram	Diagnosis Procedure	35
System Description	Special Repair Requirement	39
Component Parts Location	C1109 POWER AND GROUND SYSTEM	40
Component Description	Description	40
ABS	DTC Logic	40
System Diagram	Diagnosis Procedure	40
System Description	Special Repair Requirement	41
	C1110, C1153, C1170 ABS ACTUATOR AND ELECTRIC UNIT (CONTROL UNIT)	42
	DTC Logic	42
	Diagnosis Procedure	42
	Special Repair Requirement	42

BRC
G
H
I
J
K
L
M
N
O
P

C1111 ABS MOTOR, MOTOR RELAY SYSTEM	43	C1144 INCOMPLETE STEERING ANGLE SENSOR ADJUSTMENT	67
Description	43	DTC Logic	67
DTC Logic	43	Diagnosis Procedure	67
Diagnosis Procedure	43	Special Repair Requirement	67
Special Repair Requirement	44	C1145, C1146 YAW RATE/SIDE G SENSOR...	68
C1115 WHEEL SENSOR	45	Description	68
Description	45	DTC Logic	68
DTC Logic	45	Diagnosis Procedure	68
Diagnosis Procedure	45	Special Repair Requirement	70
Special Repair Requirement	49	C1147, C1148, C1149, C1150 USV/HSV LINE..	71
C1116 STOP LAMP SWITCH	50	Description	71
Description	50	DTC Logic	71
DTC Logic	50	Diagnosis Procedure	71
Diagnosis Procedure	50	Special Repair Requirement	72
Component Inspection	53	C1155 BRAKE FLUID LEVEL SWITCH	73
Special Repair Requirement	53	Description	73
C1120, C1122, C1124, C1126 IN ABS SOL	55	DTC Logic	73
Description	55	Diagnosis Procedure	73
DTC Logic	55	Component Inspection	75
Diagnosis Procedure	55	Special Repair Requirement	75
Special Repair Requirement	56	C1185 ICC UNIT	76
C1121, C1123, C1125, C1127 OUT ABS SOL..	57	Description	76
Description	57	DTC Logic	76
DTC Logic	57	Diagnosis Procedure	76
Diagnosis Procedure	57	Special Repair Requirement	76
Special Repair Requirement	58	U1000 CAN COMM CIRCUIT	77
C1130, C1131, C1132 ENGINE SIGNAL	59	Description	77
Description	59	DTC Logic	77
DTC Logic	59	Diagnosis Procedure	77
Diagnosis Procedure	59	Special Repair Requirement	77
Special Repair Requirement	59	U1002 SYSTEM COMM (CAN)	78
C1138 4WAS SYSTEM	60	Description	78
Description	60	DTC Logic	78
DTC Logic	60	Diagnosis Procedure	78
Diagnosis Procedure	60	Special Repair Requirement	79
Special Repair Requirement	60	POWER SUPPLY AND GROUND CIRCUIT	80
C1140 ACTUATOR RELAY SYSTEM	61	Description	80
Description	61	Diagnosis Procedure	80
DTC Logic	61	PARKING BRAKE SWITCH	82
Diagnosis Procedure	61	Description	82
Special Repair Requirement	62	Component Function Check	82
C1142 PRESS SENSOR	63	Diagnosis Procedure	82
Description	63	Component Inspection	82
DTC Logic	63	VDC OFF SWITCH	84
Diagnosis Procedure	63	Description	84
Special Repair Requirement	64	Component Function Check	84
C1143 STEERING ANGLE SENSOR	65	Diagnosis Procedure	84
Description	65	Component Inspection	85
DTC Logic	65	ABS WARNING LAMP	86
Diagnosis Procedure	65	Description	86
Special Repair Requirement	66		

Component Function Check	86	Precaution for Brake System	112	
Diagnosis Procedure	86	Precaution for Brake Control	112	A
BRAKE WARNING LAMP	87	Precautions for Harness Repair	113	
Description	87	PREPARATION	114	B
Component Function Check	87	PREPARATION	114	
Diagnosis Procedure	87	Special Service Tool	114	C
VDC OFF INDICATOR LAMP	88	Commercial Service Tool	114	
Description	88	REMOVAL AND INSTALLATION	115	D
Component Function Check	88	WHEEL SENSOR	115	
Diagnosis Procedure	88	Exploded View	115	E
VDC WARNING LAMP	89	Removal and Installation	115	
Description	89	SENSOR ROTOR	116	
Component Function Check	89	FRONT SENSOR ROTOR	116	
Diagnosis Procedure	89	FRONT SENSOR ROTOR : Exploded View	116	BRC
ECU DIAGNOSIS INFORMATION	90	FRONT SENSOR ROTOR : Removal and Installation	116	
ABS ACTUATOR AND ELECTRIC UNIT (CONTROL UNIT)	90	REAR SENSOR ROTOR	116	G
Reference Value	90	REAR SENSOR ROTOR : Exploded View	116	
Wiring Diagram - BRAKE CONTROL SYSTEM -	94	REAR SENSOR ROTOR : Removal and Installation	116	H
Fail-Safe	101	ABS ACTUATOR AND ELECTRIC UNIT (CONTROL UNIT)	118	I
DTC No. Index	102	Exploded View	118	
SYMPTOM DIAGNOSIS	104	Removal and Installation	118	
EXCESSIVE ABS FUNCTION OPERATION FREQUENCY	104	YAW RATE/SIDE G SENSOR	120	J
Diagnosis Procedure	104	Exploded View	120	
UNEXPECTED PEDAL REACTION	105	Removal and Installation	120	K
Diagnosis Procedure	105	STEERING ANGLE SENSOR	121	
THE BRAKING DISTANCE IS LONG	106	Exploded View	121	L
Diagnosis Procedure	106	Removal and Installation	121	
ABS FUNCTION DOES NOT OPERATE	107	BRAKE ASSIST (WITH PREVIEW FUNCTION)		
Diagnosis Procedure	107	SYSTEM DESCRIPTION	122	M
PEDAL VIBRATION OR ABS OPERATION SOUND OCCURS	108	PREVIEW FUNCTION	122	
Diagnosis Procedure	108	System Description	122	N
VEHICLE JERKS DURING VDC/TCS/ABS CONTROL	109	Component Parts Location	123	
Diagnosis Procedure	109	Component Description	123	
NORMAL OPERATING CONDITION	110	DTC/CIRCUIT DIAGNOSIS	125	O
Description	110	PREVIEW FUNCTION	125	
PRECAUTION	111	Diagnosis Procedure	125	P
PRECAUTIONS	111	SYMPTOM DIAGNOSIS	126	
Precaution for Supplemental Restraint System (SRS) "AIR BAG" and "SEAT BELT PRE-TENSIONER"	111	NORMAL OPERATING CONDITION	126	
Precautions Necessary for Steering Wheel Rotation After Battery Disconnection	111	Description	126	
Precaution for Procedure without Cowl Top Cover.	112	PRECAUTION	127	

PRECAUTIONS	127	Precautions for Preview Function Service	127
--------------------------	------------	--	-----

BASIC INSPECTION

DIAGNOSIS AND REPAIR WORK FLOW

Work Flow

INFOID:000000006450462

PRECAUTIONS FOR DIAGNOSIS

If steering angle sensor, steering system parts, suspension system parts, ABS actuator and electric unit (control unit) or tires have been replaced, or if wheel alignment has been adjusted, be sure to adjust neutral position of steering angle sensor before driving. Refer to [BRC-9, "ADJUSTMENT OF STEERING ANGLE SENSOR NEUTRAL POSITION : Description"](#).

- A
- B
- C
- D
- E
- F
- G
- H
- I
- J
- K
- L
- M
- N
- O
- P

BRC

DIAGNOSIS AND REPAIR WORK FLOW

< BASIC INSPECTION >

[VDC/TCS/ABS]

OVERALL SEQUENCE

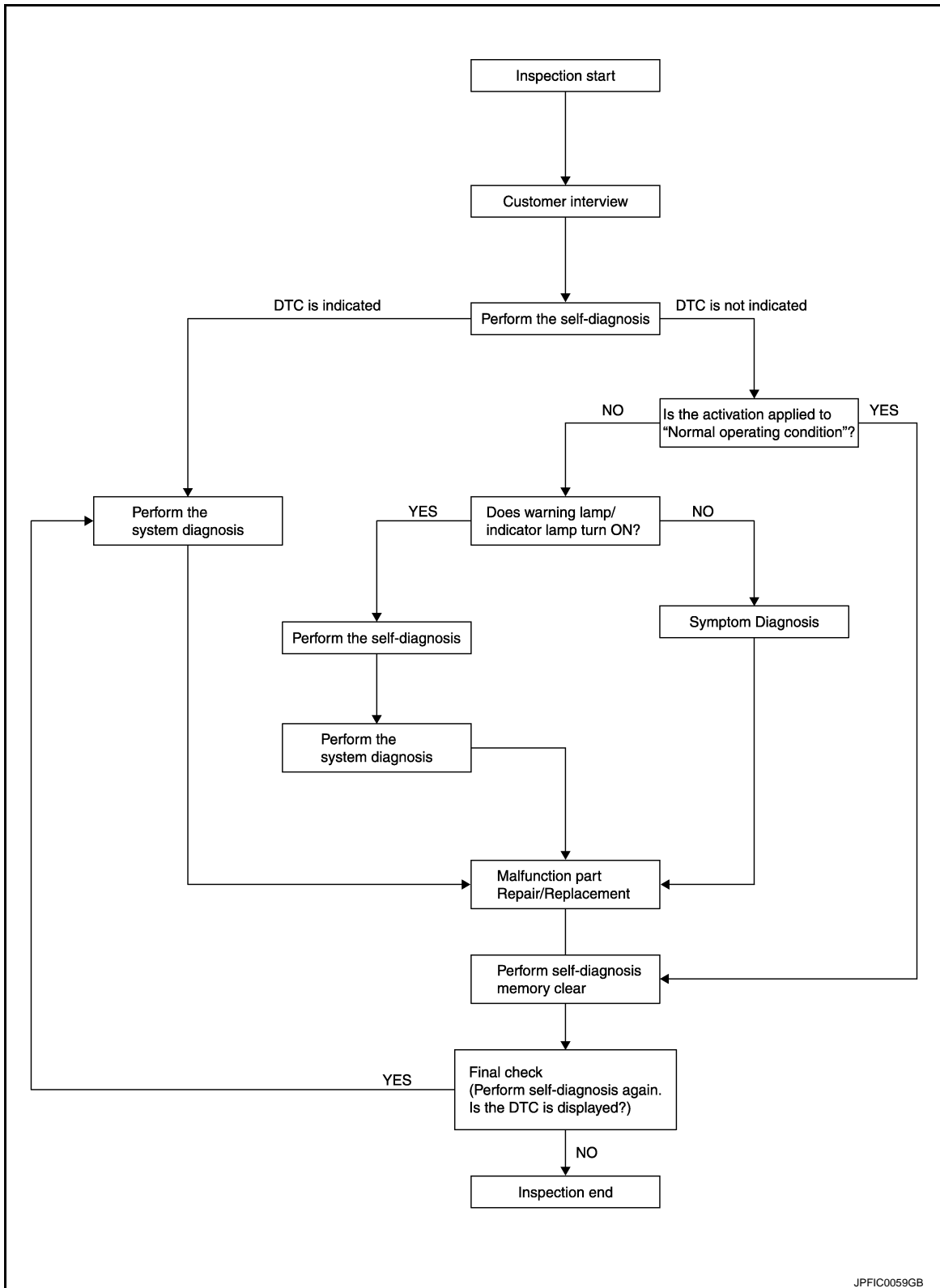

JPFIC0059GB

DETAILED FLOW

1. COLLECT THE INFORMATION FROM THE CUSTOMER

Get the detailed information from the customer about the symptom (the condition and the environment when the incident/malfunction occurred) using the diagnosis work sheet. Refer to [BRC-8, "Diagnostic Work Sheet"](#).

>> GO TO 2.

DIAGNOSIS AND REPAIR WORK FLOW

< BASIC INSPECTION >

[VDC/TCS/ABS]

2. PERFORM THE SELF-DIAGNOSIS

Perform self-diagnosis for "ABS" with CONSULT-III.

Is there any DTC displayed?

YES >> GO TO 3.

NO >> GO TO 4.

3. PERFORM THE SYSTEM DIAGNOSIS

Perform the diagnosis applicable to the displayed DTC of "ABS" with CONSULT-III. Refer to [BRC-102, "DTC No. Index"](#).

>> GO TO 7.

4. CHECK THE SYMPTOM THAT IS NOT CONSIDERED A SYSTEM MALFUNCTION

Check that the symptom is a normal operation that is not considered a system malfunction. Refer to [BRC-110, "Description"](#).

Is the symptom a normal operation?

YES >> INSPECTION END

NO >> GO TO 5.

5. CHECK THE WARNING LAMP AND INDICATOR LAMP FOR ILLUMINATION

Check that the warning lamp and indicator lamp illuminate.

- ABS warning lamp: Refer to [BRC-86, "Description"](#).
- Brake warning lamp: Refer to [BRC-87, "Description"](#).
- VDC OFF indicator lamp: Refer to [BRC-88, "Description"](#).
- VDC warning lamp: Refer to [BRC-89, "Description"](#).

Is ON/OFF timing normal?

YES >> GO TO 6.

NO >> GO TO 2.

6. PERFORM THE DIAGNOSIS BY SYMPTOM

Perform self-diagnosis for "ABS" with CONSULT-III.

>> GO TO 7.

7. REPAIR OR REPLACE THE MALFUNCTIONING PARTS

Repair or replace the specified malfunctioning parts.

>> GO TO 8.

8. MEMORY CLEAR

Perform self-diagnosis memory clear for "ABS" with CONSULT-III.

>> GO TO 9.

9. FINAL CHECK

Perform the self-diagnosis again, and check that the malfunction is repaired completely.

Is no other DTC present and the repair completed?

YES >> INSPECTION END

NO >> GO TO 3.

A
B
C
D
E
G
H
I
J
K
L
M
N
O
P

BRC

DIAGNOSIS AND REPAIR WORK FLOW

< BASIC INSPECTION >

[VDC/TCS/ABS]

Diagnostic Work Sheet

INFOID:000000006450463

Customer name MR/MS	Model & Year	VIN	
Engine #	Trans.	Mileage	
Incident Date	Manuf. Date	In Service Date	
Symptoms	<input type="checkbox"/> Noise and vibration (from engine compartment) <input type="checkbox"/> Noise and vibration (from axle)	<input type="checkbox"/> Warning / Indicator activate	<input type="checkbox"/> Firm pedal operation <input type="checkbox"/> Large stroke pedal operation
	<input type="checkbox"/> TCS does not work (Rear wheels slip when accelerating)	<input type="checkbox"/> ABS does not work (Wheels lock when braking)	<input type="checkbox"/> Lack of sense of acceleration
Engine conditions	<input type="checkbox"/> When starting <input type="checkbox"/> After starting		
Road conditions	<input type="checkbox"/> Low friction road (<input type="checkbox"/> Snow <input type="checkbox"/> Gravel <input type="checkbox"/> Other) <input type="checkbox"/> Bumps / potholes		
Driving conditions	<input type="checkbox"/> Full-acceleration <input type="checkbox"/> High speed cornering <input type="checkbox"/> Vehicle speed: Greater than 10 km/h (6 MPH) <input type="checkbox"/> Vehicle speed: 10 km/h (6 MPH) or less <input type="checkbox"/> Vehicle is stopped		
Applying brake conditions	<input type="checkbox"/> Suddenly <input type="checkbox"/> Gradually		
Other conditions	<input type="checkbox"/> Operation of electrical equipment <input type="checkbox"/> Shift change <input type="checkbox"/> Other descriptions		

SFIA3265E

INSPECTION AND ADJUSTMENT

< BASIC INSPECTION >

[VDC/TCS/ABS]

INSPECTION AND ADJUSTMENT

ADDITIONAL SERVICE WHEN REPLACING CONTROL UNIT

ADDITIONAL SERVICE WHEN REPLACING CONTROL UNIT : Description

INFOID:000000006450464

After replacing the ABS actuator and electric unit (control unit), perform the neutral position adjustment for the steering angle sensor.

ADDITIONAL SERVICE WHEN REPLACING CONTROL UNIT : Special Repair Requirement

INFOID:000000006450465

1. PERFORM THE NEUTRAL POSITION ADJUSTMENT FOR THE STEERING ANGLE SENSOR

Perform the neutral position adjustment for the steering angle sensor.

>> Refer to [BRC-9, "ADJUSTMENT OF STEERING ANGLE SENSOR NEUTRAL POSITION : Special Repair Requirement"](#).

ADJUSTMENT OF STEERING ANGLE SENSOR NEUTRAL POSITION

ADJUSTMENT OF STEERING ANGLE SENSOR NEUTRAL POSITION : Description

INFOID:000000006450466

In case of doing work that applies to the list below, make sure to adjust neutral position of steering angle sensor before running vehicle.

x: Required –: Not required

Situation	Adjustment of steering angle sensor neutral position
Removing/Installing ABS actuator and electric unit (control unit)	—
Replacing ABS actuator and electric unit (control unit)	x
Removing/Installing steering angle sensor	x
Replacing steering angle sensor	x
Removing/Installing 4WAS components	x
Replacing 4WAS components	x
Removing/Installing steering components	x
Replacing steering components	x
Removing/Installing suspension components	x
Replacing suspension components	x
Change tires to new ones	—
Tire rotation	—
Adjusting wheel alignment	x

ADJUSTMENT OF STEERING ANGLE SENSOR NEUTRAL POSITION : Special Repair Requirement

INFOID:000000006450467

ADJUSTMENT OF STEERING ANGLE SENSOR NEUTRAL POSITION

CAUTION:

**To adjust neutral position of steering angle sensor, make sure to use CONSULT-III.
(Adjustment cannot be done without CONSULT-III.)**

1. ALIGN THE VEHICLE STATUS

Stop the vehicle with front wheels in straight-ahead position.

>> GO TO 2.

2. PERFORM THE NEUTRAL POSITION ADJUSTMENT FOR THE STEERING ANGLE SENSOR

INSPECTION AND ADJUSTMENT

[VDC/TCS/ABS]

< BASIC INSPECTION >

1. Select "ABS", "WORK SUPPORT" and "ST ANGLE SENSOR ADJUSTMENT" in order with CONSULT-III.
2. Select "START".

CAUTION:

Do not touch steering wheel while adjusting steering angle sensor.

3. After approximately 10 seconds, select "END".

NOTE:

After approximately 60 seconds, it ends automatically.

4. Turn ignition switch OFF, then turn it ON again.

CAUTION:

Be sure to perform above operation.

>> GO TO 3.

3. CHECK DATA MONITOR

1. Run the vehicle with front wheels in straight-ahead position, then stop.
2. Select "ABS", "DATA MONITOR" and "STR ANGLE SIG" in order with CONSULT-III, and check steering angle sensor signal.

STR ANGLE SIG : $0 \pm 2.5^\circ$

Is the steering angle within the specified range?

YES >> GO TO 4.

NO >> Perform the neutral position adjustment for the steering angle sensor again, GO TO 1.

4. ERASE THE SELF-DIAGNOSIS MEMORY

Erase the self-diagnosis memories for "ABS", "ENGINE", "4WAS(FRONT)", "4WAS(MAIN)/RAS/HICAS" and "ICC/ADAS" with CONSULT-III.

- "ABS": Refer to [BRC-27, "CONSULT-III Function"](#).
- "ENGINE": Refer to [EC-145, "CONSULT-III Function"](#).
- "4WAS(MAIN)/RAS/HICAS": Refer to [STC-45, "CONSULT-III Function \[4WAS\(MAIN\)/RAS/HICAS\]"](#).
- "4WAS(FRONT)": Refer to [STC-41, "CONSULT-III Function \[4WAS\(FRONT\)\]"](#).
- "ICC/ADAS": Refer to [CCS-36, "CONSULT-III Function \(ICC/ADAS\)"](#).

Are the memories erased?

YES >> INSPECTION END

NO >> Check the items indicated by the self-diagnosis.

SYSTEM DESCRIPTION

VDC

System Diagram

INFOID:000000006450468

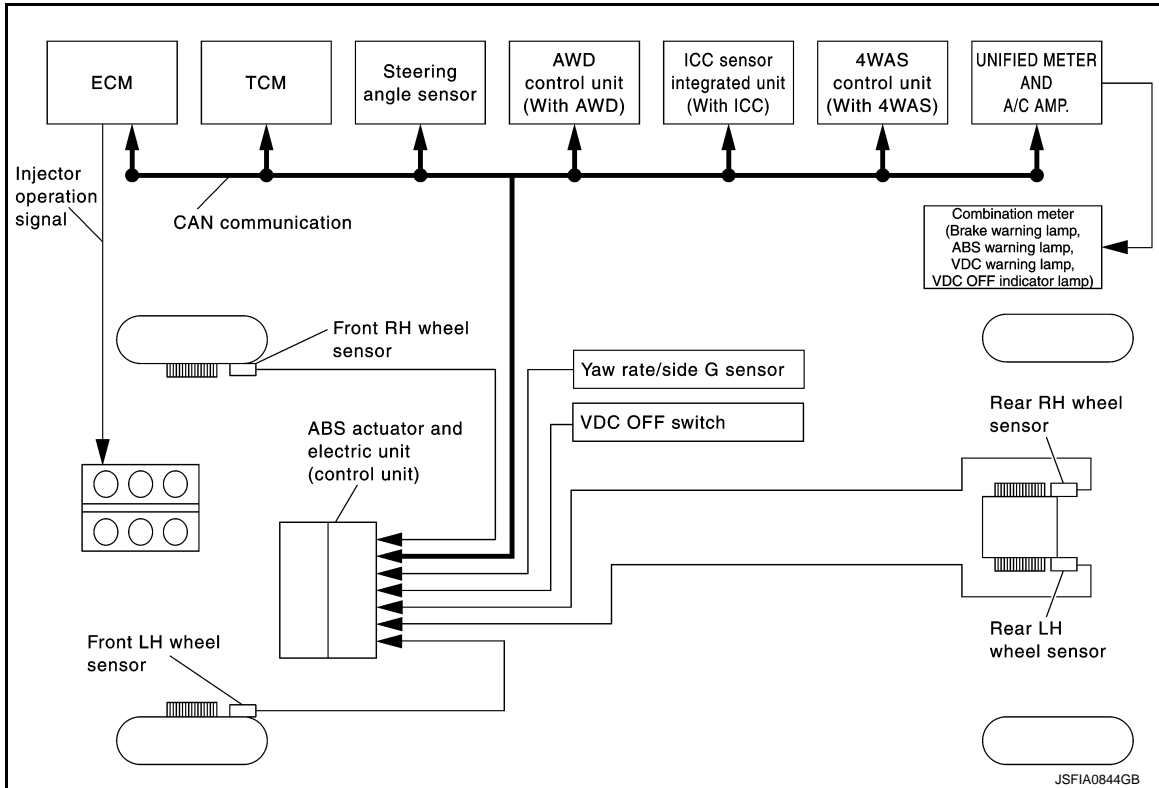

System Description

INFOID:000000006450469

- Vehicle Dynamics Control system detects driver's steering operation amount and brake pedal travel from steering angle sensor and pressure sensor. Using information from yaw rate/side G sensor and wheel sensor, VDC judges driving condition (conditions of under steer and over steer) to improve vehicle driving stability by controlling brake application to 4 wheels and engine output.
- During VDC operation, it informs driver of system operation by flashing VDC warning lamp.
- Electrical system diagnosis by CONSULT-III is available.

For USA

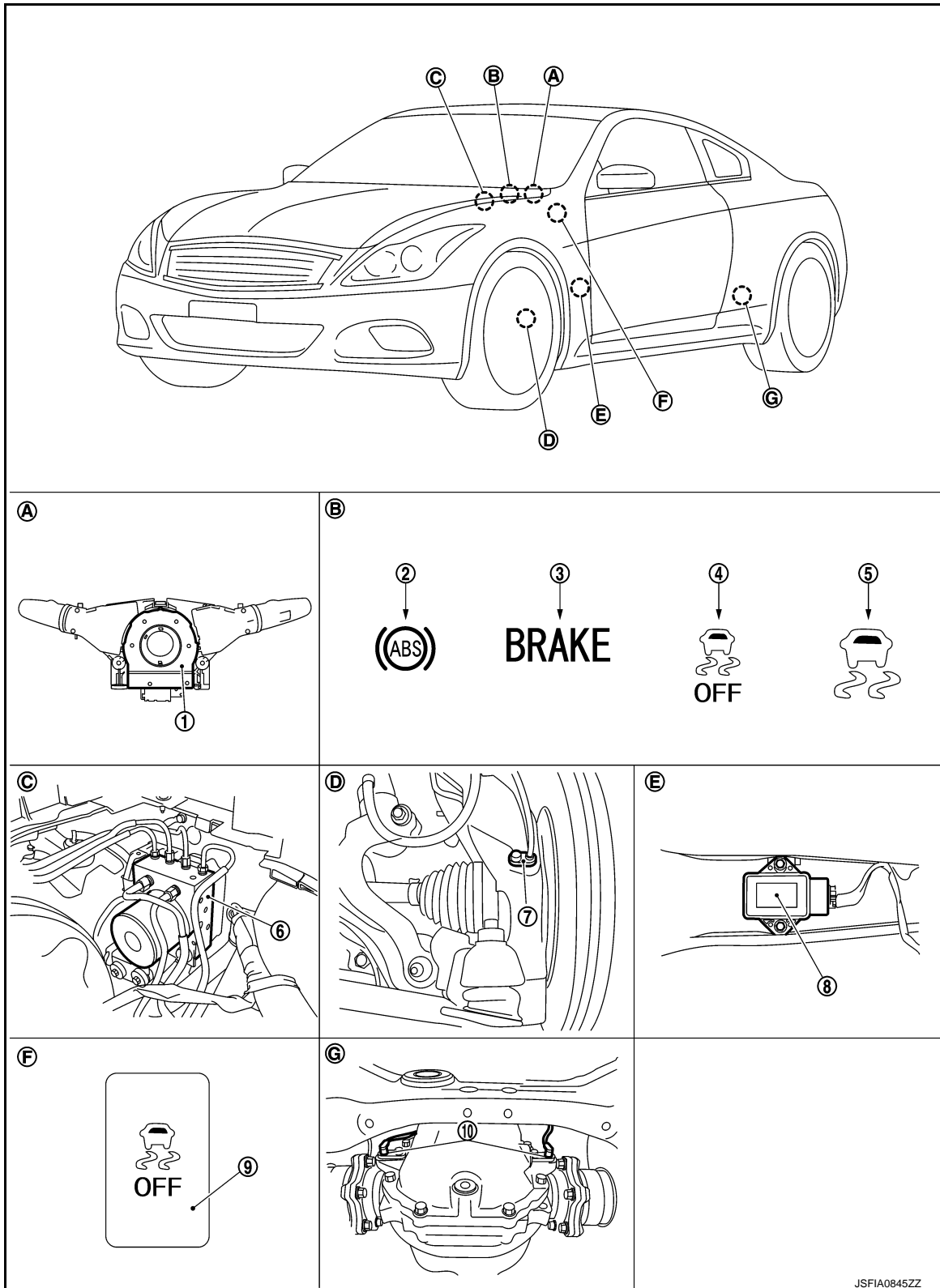

- | | | |
|---------------------------|---------------------|--|
| 1. Steering angle sensor | 2. ABS warning lamp | 3. Brake warning lamp |
| 4. VDC OFF indicator lamp | 5. VDC warning lamp | 6. ABS actuator and electric unit (control unit) |

JSFIA0845ZZ

VDC

[VDC/TCS/ABS]

< SYSTEM DESCRIPTION >

- 7. Front wheel sensor
- 8. Yaw rate/side G sensor
- 9. VDC OFF switch
- 10. Rear wheel sensor

- A. Back of spiral cable assembly
- B. Combination meter
- C. Inside brake master cylinder cover
- D. Steering knuckle
- E. Under center console
- F. Instrument driver lower panel
- G. Rear final drive assembly

For Canada

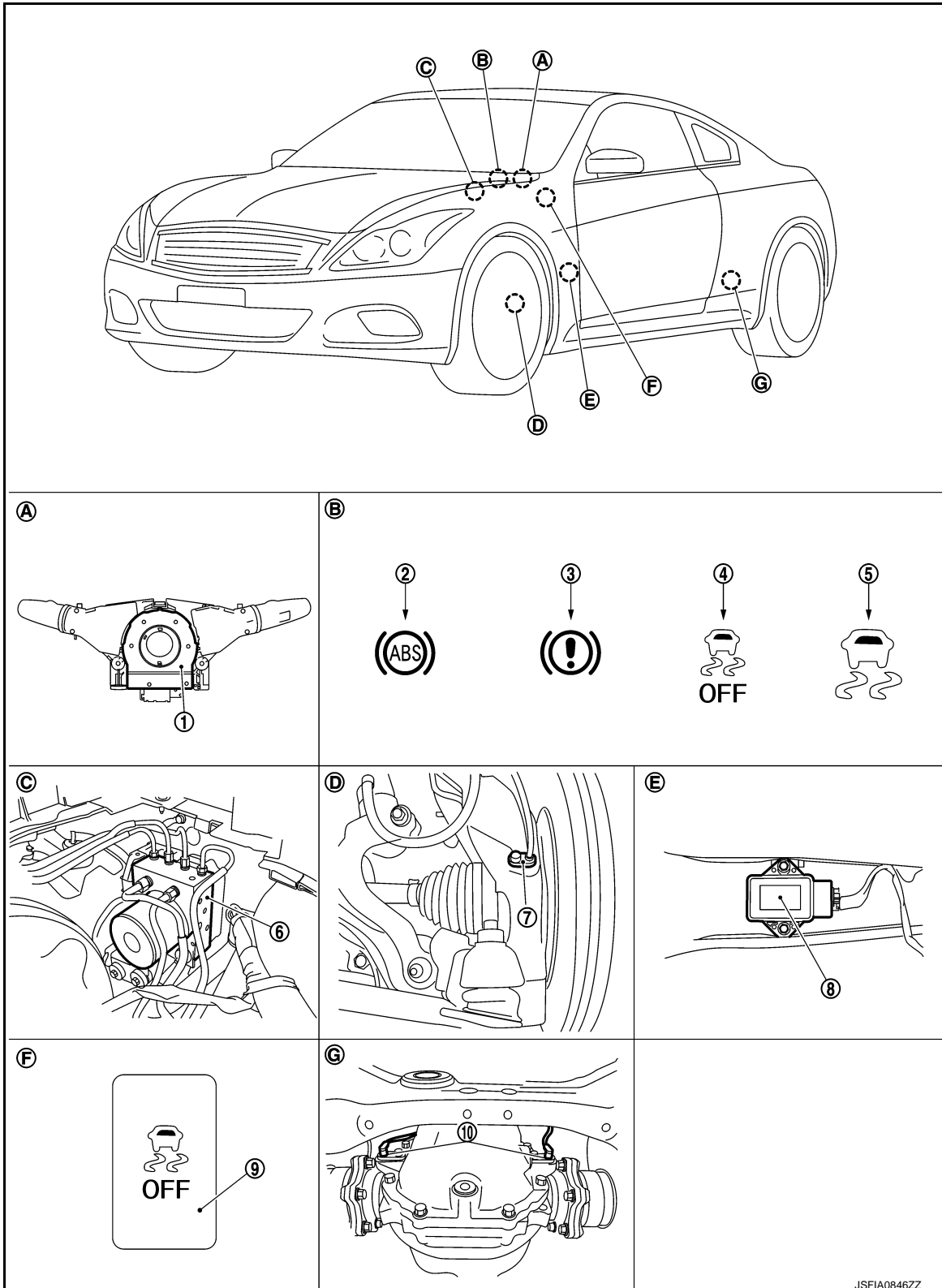

A
B
C
D
E
G
H
I
J
K
L
M
N
O
P

BRC

JSFIA0846ZZ

< SYSTEM DESCRIPTION >

- | | | |
|----------------------------------|---------------------------|--|
| 1. Steering angle sensor | 2. ABS warning lamp | 3. Brake warning lamp |
| 4. VDC OFF indicator lamp | 5. VDC warning lamp | 6. ABS actuator and electric unit (control unit) |
| 7. Front wheel sensor | 8. Yaw rate/side G sensor | 9. VDC OFF switch |
| 10. Rear wheel sensor | | |
| A. Back of spiral cable assembly | B. Combination meter | C. Inside brake master cylinder cover |
| D. Steering knuckle | E. Under center console | F. Instrument driver lower panel |
| G. Rear final drive assembly | | |

Component Description

INFOID:000000006450471

Component parts	Reference	
ABS actuator and electric unit (control unit)	Pump	BRC-43. "Description"
	Motor	
	Actuator relay (Main relay)	BRC-61. "Description"
	Solenoid valve	BRC-55. "Description"
	Pressure sensor	BRC-63. "Description"
	VDC switch-over valve (USV1, USV2, HSV1, HSV2)	BRC-71. "Description"
Wheel sensor	BRC-43. "Description"	
Yaw rate/side G sensor	BRC-68. "Description"	
Steering angle sensor	BRC-65. "Description"	
VDC OFF switch	BRC-84. "Description"	
ABS warning lamp	BRC-86. "Description"	
Brake warning lamp	BRC-87. "Description"	
VDC OFF indicator lamp	BRC-88. "Description"	
VDC warning lamp	BRC-89. "Description"	

TCS

System Diagram

INFOID:000000006946392

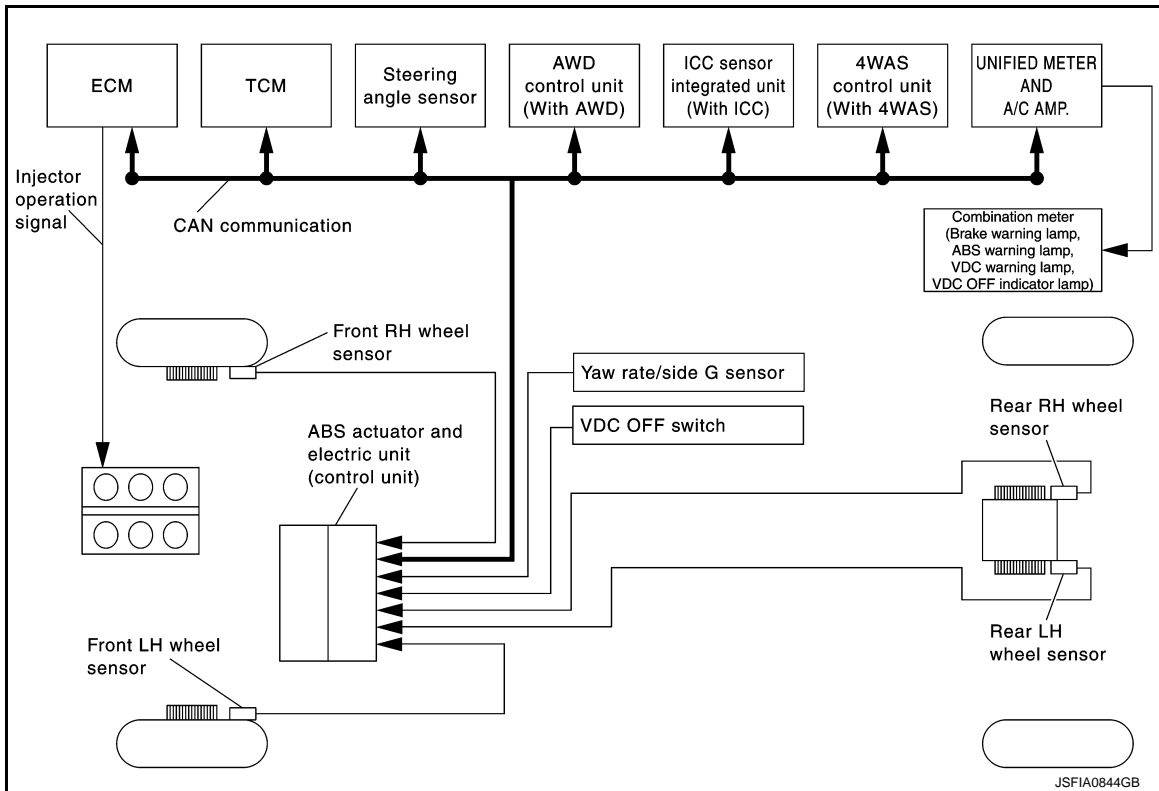

System Description

INFOID:000000006450473

- Traction Control System is a function that electronically controls engine torque, brake fluid pressure and A/T gear position to ensure the optimum slippage ratio at drive wheels by computing wheel speed signals from 4 wheel sensors. When ABS actuator and electric unit (control unit) detects a spin at drive wheels (rear wheels), it compares wheel speed signals from all 4 wheels. At this time, LH and RH rear brake fluid pressure are controlled, while fuel being cut to engine and throttle valve being closed to reduce engine torque by the control unit. Further more, throttle position is continuously controlled to ensure the optimum engine torque at all times.
- During TCS operation, it informs driver of system operation by flashing VDC warning lamp.
- Electrical system diagnosis by CONSULT-III is available.

For USA

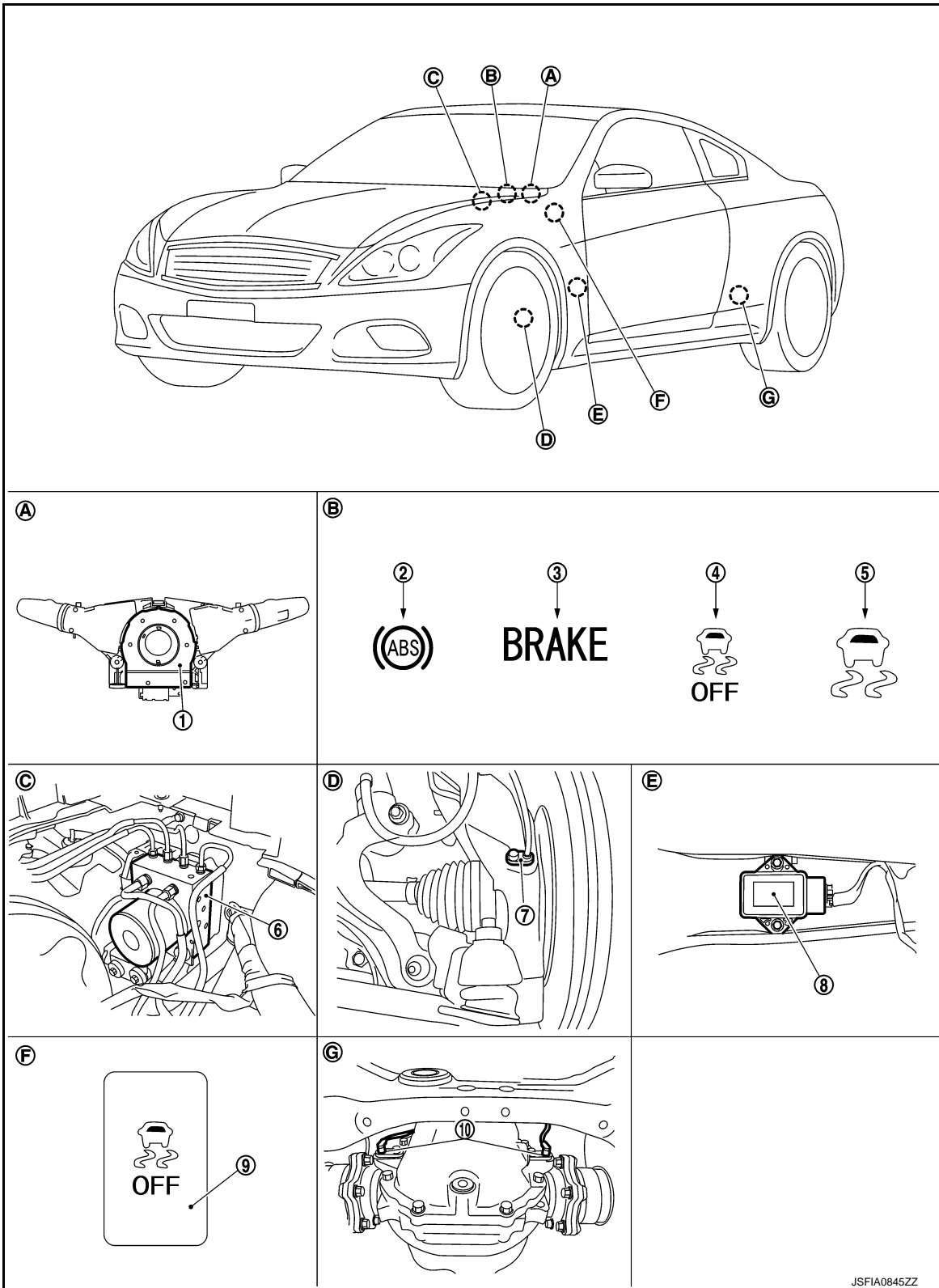

- | | | |
|---------------------------|---------------------|--|
| 1. Steering angle sensor | 2. ABS warning lamp | 3. Brake warning lamp |
| 4. VDC OFF indicator lamp | 5. VDC warning lamp | 6. ABS actuator and electric unit (control unit) |

JSFIA0845ZZ

TCS

[VDC/TCS/ABS]

< SYSTEM DESCRIPTION >

- 7. Front wheel sensor
- 8. Yaw rate/side G sensor
- 9. VDC OFF switch
- 10. Rear wheel sensor

- A. Back of spiral cable assembly
- B. Combination meter
- C. Inside brake master cylinder cover
- D. Steering knuckle
- E. Under center console
- F. Instrument driver lower panel
- G. Rear final drive assembly

For Canada

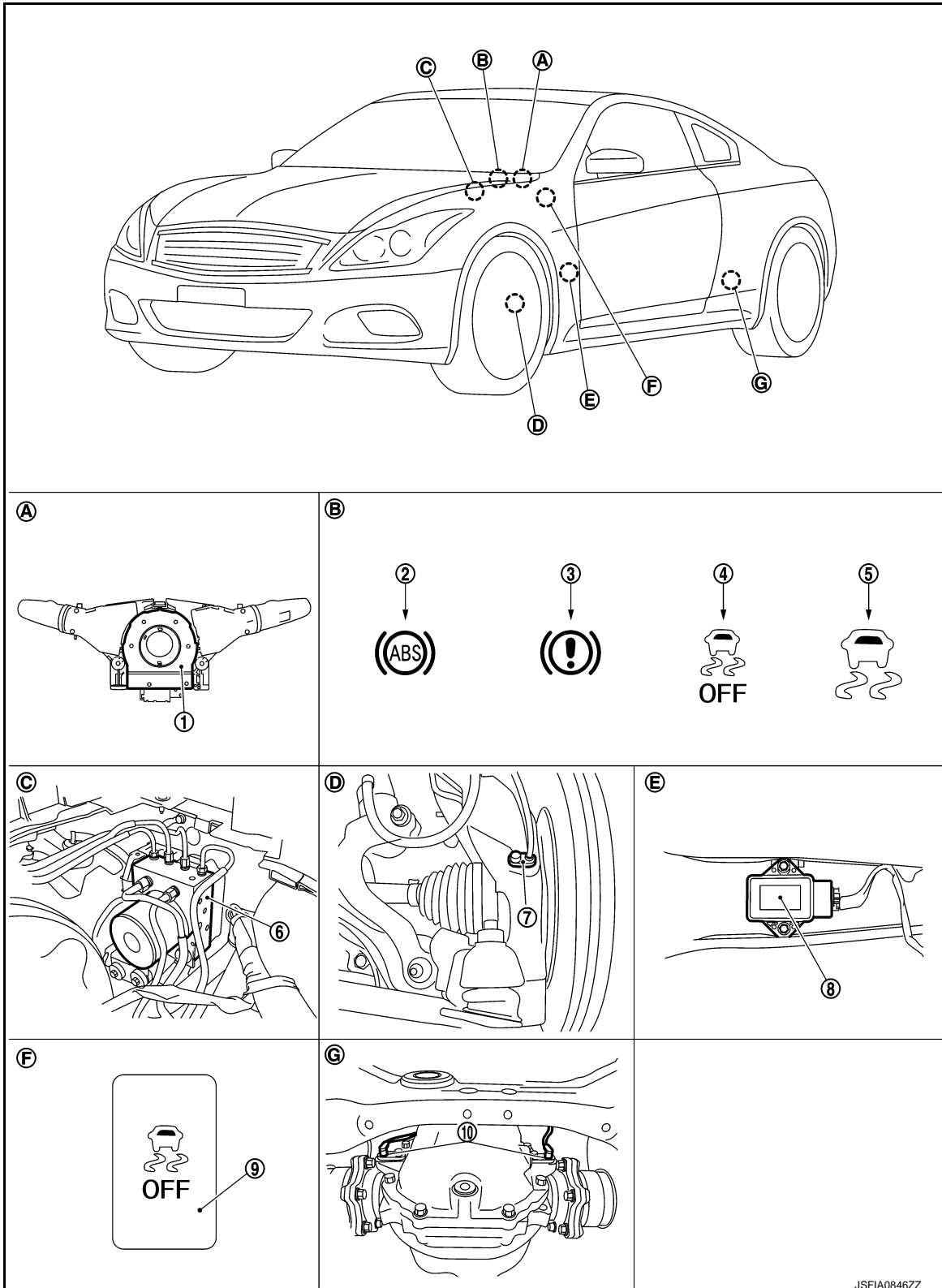

A
B
C
D
E
G
H
I
J
K
L
M
N
O
P

BRC

JSFIA0846ZZ

< SYSTEM DESCRIPTION >

- | | | |
|----------------------------------|---------------------------|--|
| 1. Steering angle sensor | 2. ABS warning lamp | 3. Brake warning lamp |
| 4. VDC OFF indicator lamp | 5. VDC warning lamp | 6. ABS actuator and electric unit (control unit) |
| 7. Front wheel sensor | 8. Yaw rate/side G sensor | 9. VDC OFF switch |
| 10. Rear wheel sensor | | |
| A. Back of spiral cable assembly | B. Combination meter | C. Inside brake master cylinder cover |
| D. Steering knuckle | E. Under center console | F. Instrument driver lower panel |
| G. Rear final drive assembly | | |

Component Description

INFOID:000000006450475

Component parts		Reference
ABS actuator and electric unit (control unit)	Pump	BRC-43. "Description"
	Motor	
	Actuator relay (Main relay)	BRC-61. "Description"
	Solenoid valve	BRC-55. "Description"
	Pressure sensor	BRC-63. "Description"
	VDC switch-over valve (USV1, USV2, HSV1, HSV2)	BRC-71. "Description"
Wheel sensor	BRC-32. "Description"	
Yaw rate/side G sensor	BRC-68. "Description"	
Steering angle sensor	BRC-65. "Description"	
VDC OFF switch	BRC-84. "Description"	
ABS warning lamp	BRC-86. "Description"	
Brake warning lamp	BRC-87. "Description"	
VDC OFF indicator lamp	BRC-88. "Description"	
VDC warning lamp	BRC-89. "Description"	

ABS

System Diagram

INFOID:000000006946394

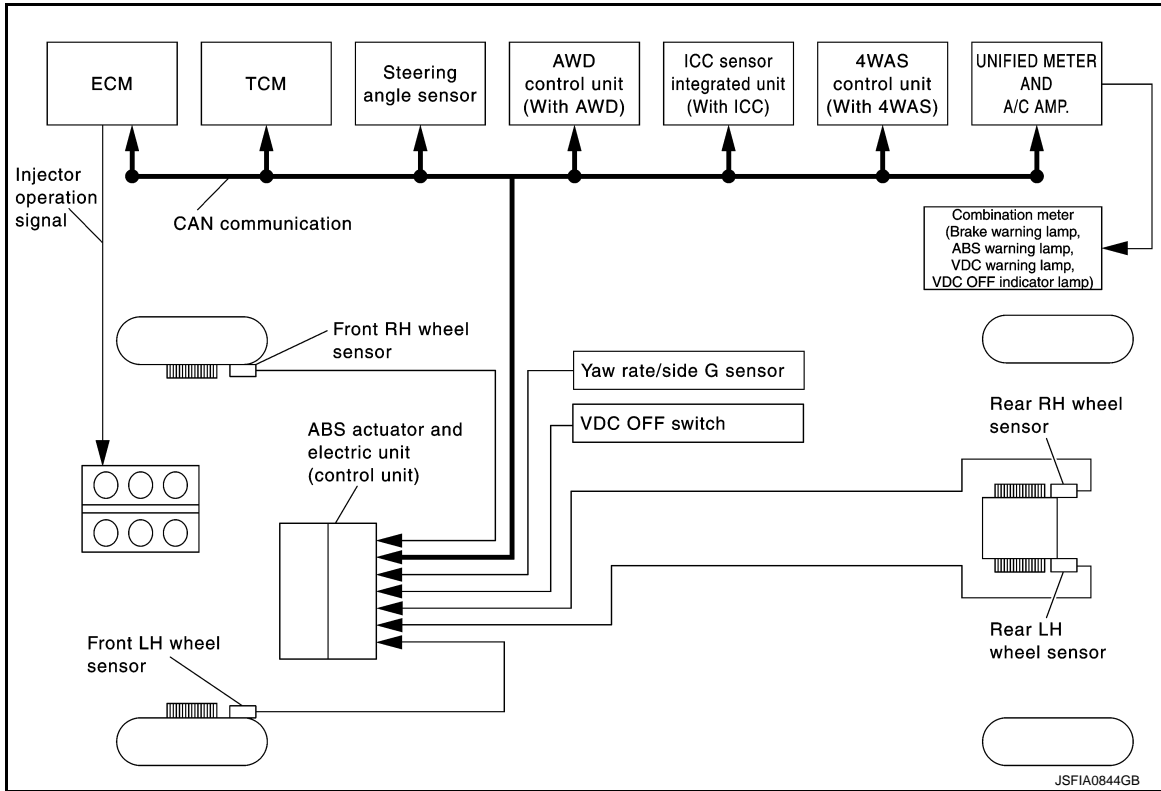

System Description

INFOID:000000006450477

- Anti-Lock Braking System is a function that detects wheel revolution while braking, electronically controls braking force, and prevents wheel locking during sudden braking. It improves handling stability and maneuverability for avoiding obstacles.
- Electrical system diagnosis by CONSULT-III is available.

A
B
C
D
E
BRC
G
H
I
J
K
L
M
N
O
P

ABS

< SYSTEM DESCRIPTION >

[VDC/TCS/ABS]

Component Parts Location

INFOID:000000006946395

For USA

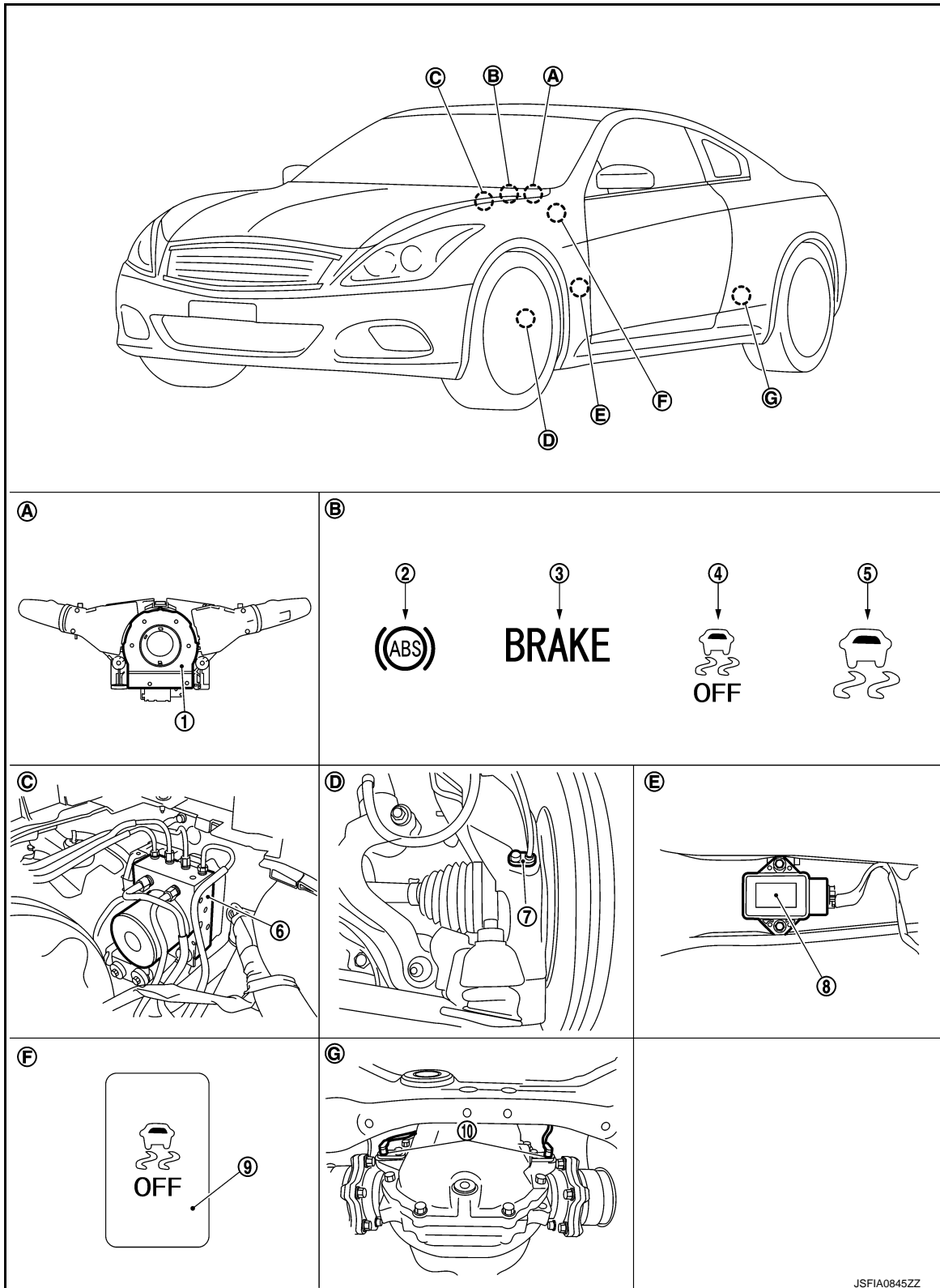

1. Steering angle sensor
4. VDC OFF indicator lamp

2. ABS warning lamp
5. VDC warning lamp

3. Brake warning lamp
6. ABS actuator and electric unit (control unit)

ABS

[VDC/TCS/ABS]

< SYSTEM DESCRIPTION >

- 7. Front wheel sensor
- 10. Rear wheel sensor

- 8. Yaw rate/side G sensor

- 9. VDC OFF switch

- A. Back of spiral cable assembly
- D. Steering knuckle
- G. Rear final drive assembly

- B. Combination meter
- E. Under center console

- C. Inside brake master cylinder cover
- F. Instrument driver lower panel

For Canada

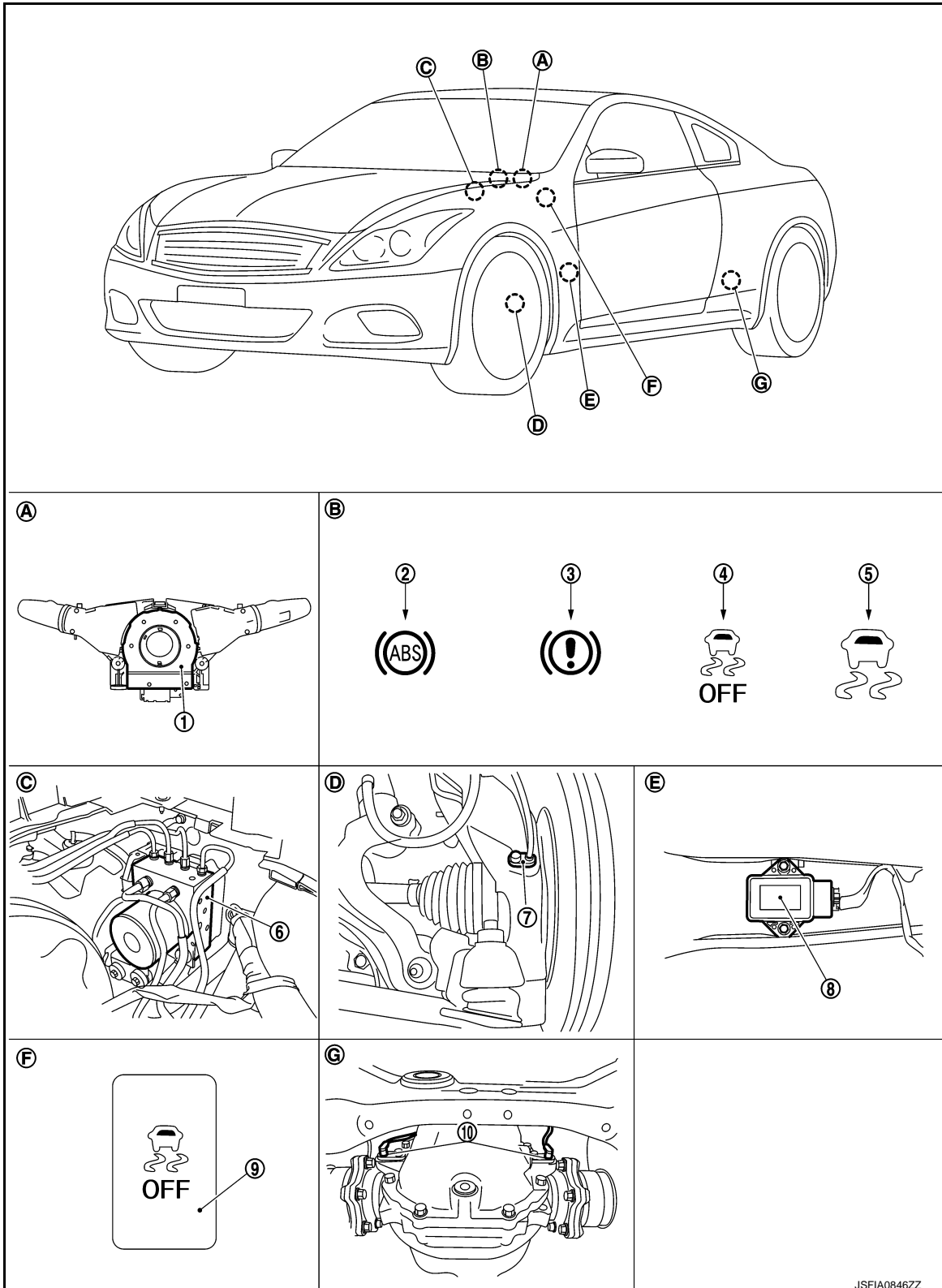

A
B
C
D
E
G
H
I
J
K
L
M
N
O
P

BRC

JSFIA0846ZZ

ABS

[VDC/TCS/ABS]

< SYSTEM DESCRIPTION >

- | | | |
|----------------------------------|---------------------------|--|
| 1. Steering angle sensor | 2. ABS warning lamp | 3. Brake warning lamp |
| 4. VDC OFF indicator lamp | 5. VDC warning lamp | 6. ABS actuator and electric unit (control unit) |
| 7. Front wheel sensor | 8. Yaw rate/side G sensor | 9. VDC OFF switch |
| 10. Rear wheel sensor | | |
| A. Back of spiral cable assembly | B. Combination meter | C. Inside brake master cylinder cover |
| D. Steering knuckle | E. Under center console | F. Instrument driver lower panel |
| G. Rear final drive assembly | | |

Component Description

INFOID:000000006450479

Component parts	Reference	
ABS actuator and electric unit (control unit)	Pump	BRC-43. "Description"
	Motor	
	Actuator relay (Main relay)	BRC-61. "Description"
	Solenoid valve	BRC-55. "Description"
	Pressure sensor	BRC-63. "Description"
	VDC switch-over valve (USV1, USV2, HSV1, HSV2)	BRC-71. "Description"
Wheel sensor	BRC-32. "Description"	
Yaw rate/side G sensor	BRC-68. "Description"	
Steering angle sensor	BRC-65. "Description"	
VDC OFF switch	BRC-84. "Description"	
ABS warning lamp	BRC-86. "Description"	
Brake warning lamp	BRC-87. "Description"	
VDC OFF indicator lamp	BRC-88. "Description"	
VDC warning lamp	BRC-89. "Description"	

EBD

System Diagram

INFOID:000000006946396

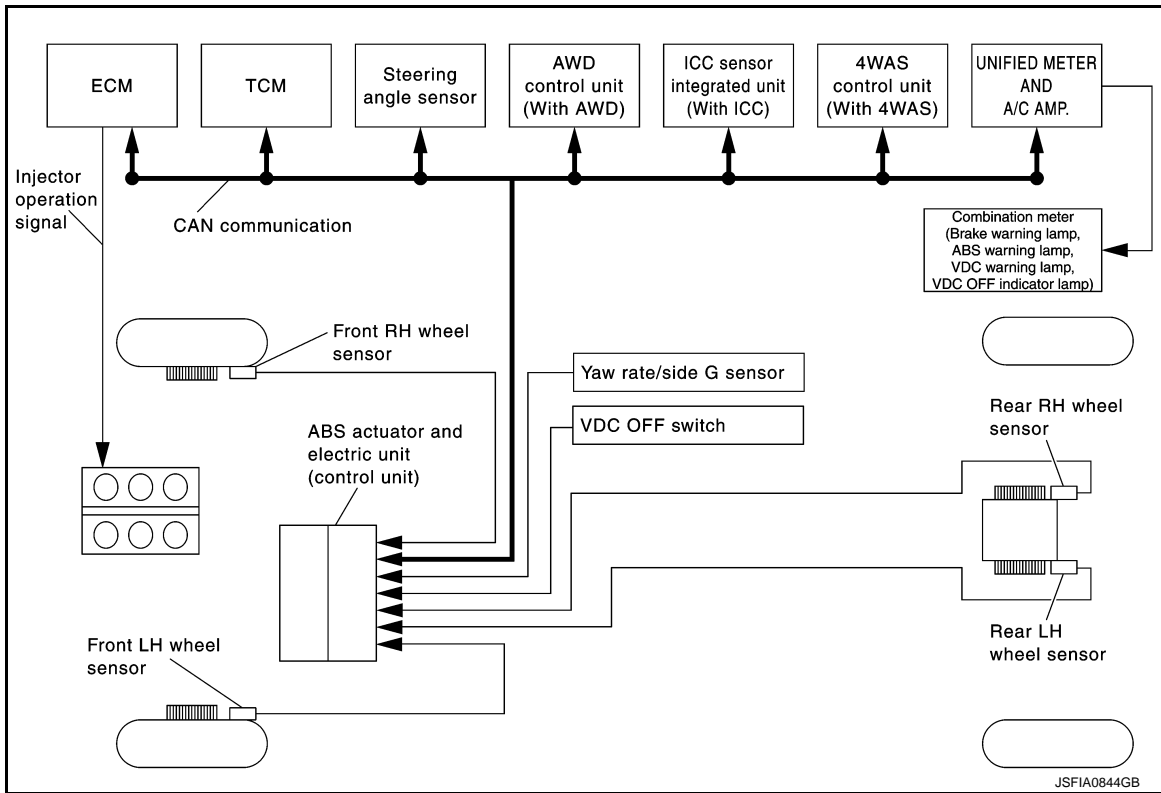

System Description

INFOID:000000006450481

- Electric Brake force Distribution is a following function. ABS actuator and electric unit (control unit) detects subtle slippages between the front and rear wheels during braking. Then is electronically controls the rear braking force (brake fluid pressure) to reducing and reduces rear wheel slippage. Accordingly it improves vehicle stability.
- Electrical system diagnosis by CONSULT-III is available.

A
B
C
D
E
BRC
G
H
I
J
K
L
M
N
O
P

For USA

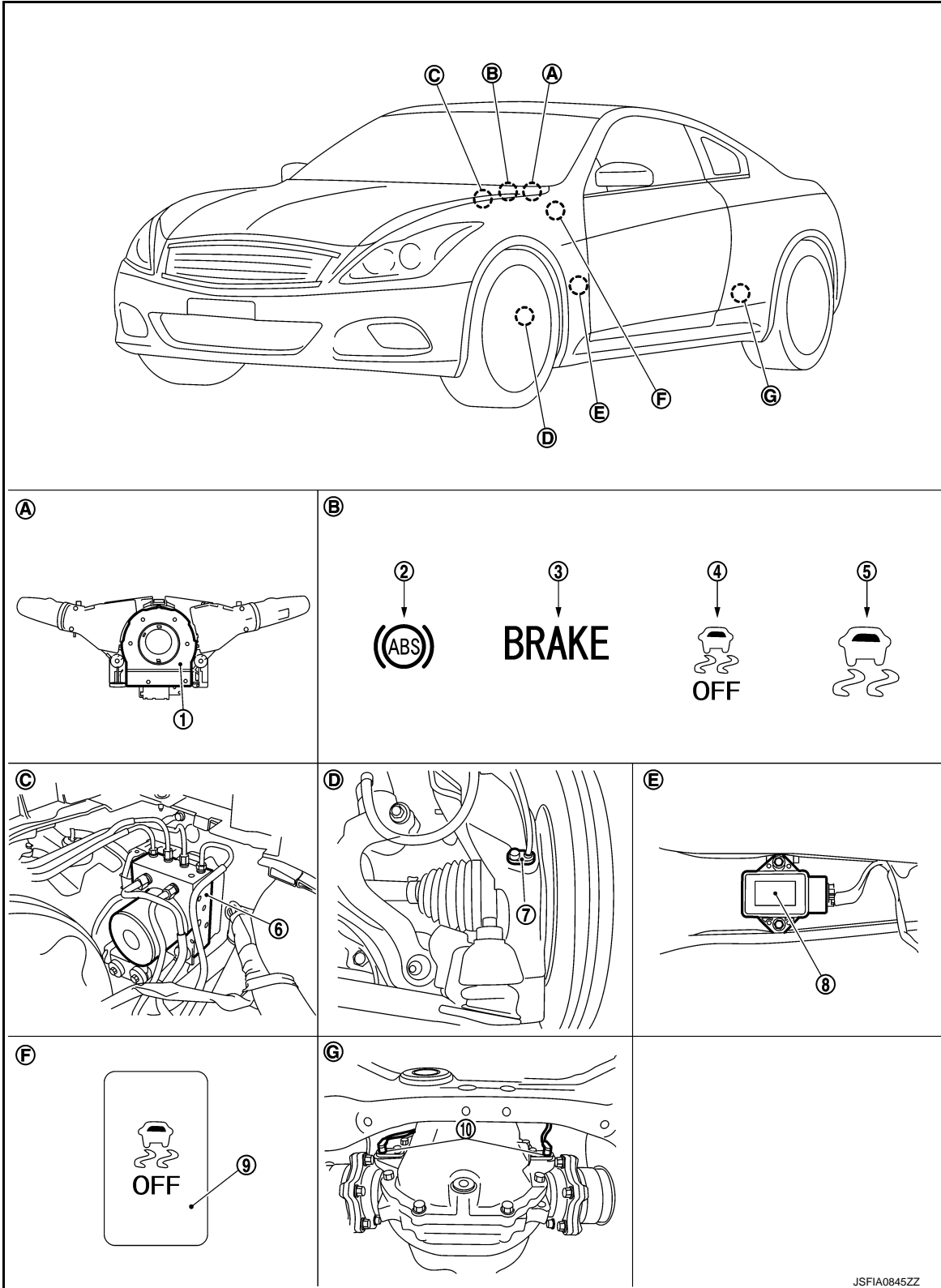

- 1. Steering angle sensor
- 2. ABS warning lamp
- 3. Brake warning lamp
- 4. VDC OFF indicator lamp
- 5. VDC warning lamp
- 6. ABS actuator and electric unit (control unit)

JSFIA0845ZZ

EBD

[VDC/TCS/ABS]

< SYSTEM DESCRIPTION >

- 7. Front wheel sensor
- 10. Rear wheel sensor

- 8. Yaw rate/side G sensor

- 9. VDC OFF switch

- A. Back of spiral cable assembly
- D. Steering knuckle
- G. Rear final drive assembly

- B. Combination meter
- E. Under center console

- C. Inside brake master cylinder cover
- F. Instrument driver lower panel

For Canada

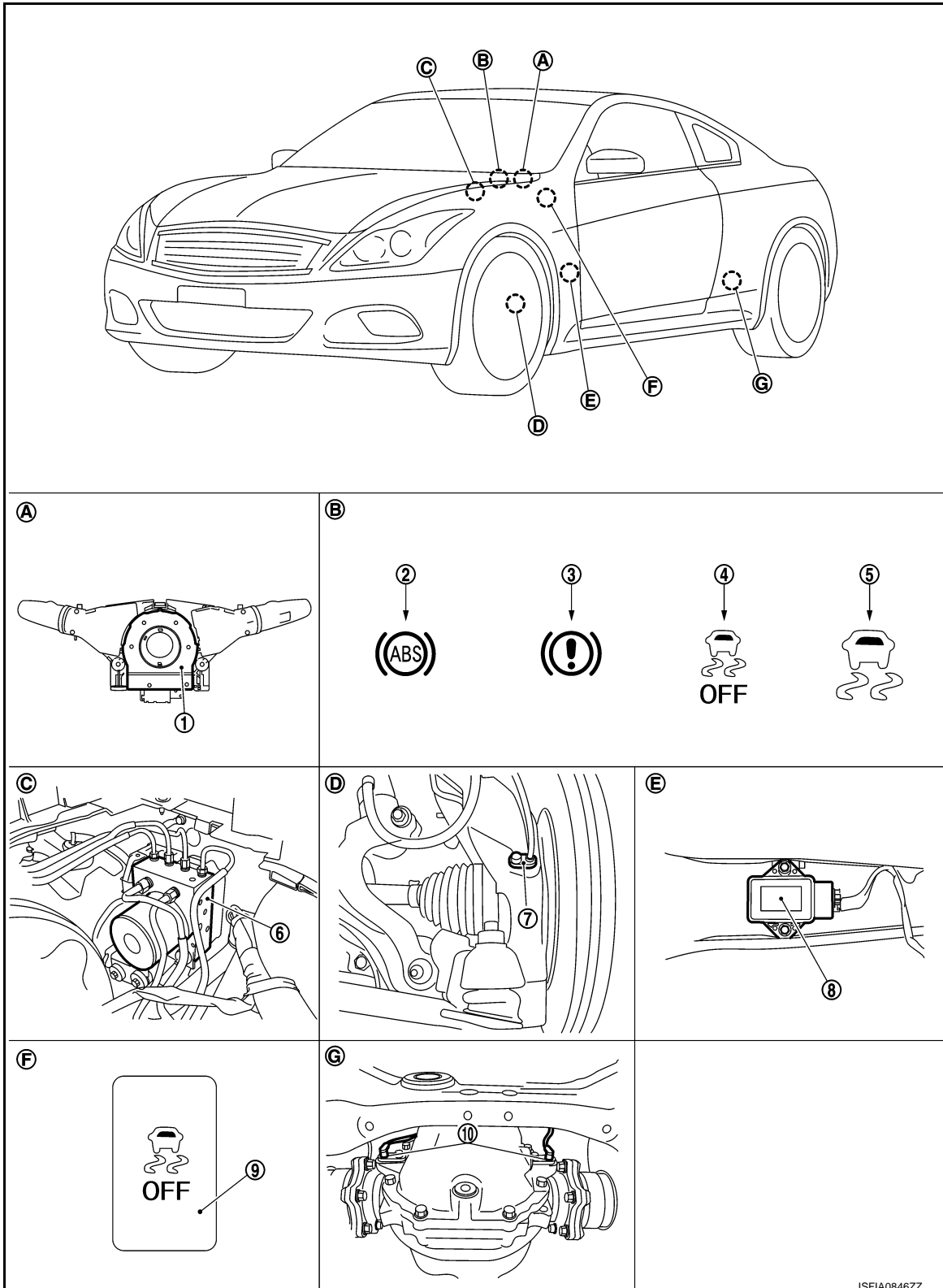

JSFIA0846ZZ

< SYSTEM DESCRIPTION >

- | | | |
|----------------------------------|---------------------------|--|
| 1. Steering angle sensor | 2. ABS warning lamp | 3. Brake warning lamp |
| 4. VDC OFF indicator lamp | 5. VDC warning lamp | 6. ABS actuator and electric unit (control unit) |
| 7. Front wheel sensor | 8. Yaw rate/side G sensor | 9. VDC OFF switch |
| 10. Rear wheel sensor | | |
| A. Back of spiral cable assembly | B. Combination meter | C. Inside brake master cylinder cover |
| D. Steering knuckle | E. Under center console | F. Instrument driver lower panel |
| G. Rear final drive assembly | | |

Component Description

INFOID:000000006450483

Component parts		Reference
ABS actuator and electric unit (control unit)	Pump	BRC-43. "Description"
	Motor	
	Actuator relay (Main relay)	BRC-61. "Description"
	Solenoid valve	BRC-55. "Description"
	Pressure sensor	BRC-63. "Description"
	VDC switch-over valve (USV1, USV2, HSV1, HSV2)	BRC-71. "Description"
Wheel sensor	BRC-32. "Description"	
Yaw rate/side G sensor	BRC-68. "Description"	
Steering angle sensor	BRC-65. "Description"	
VDC OFF switch	BRC-84. "Description"	
ABS warning lamp	BRC-86. "Description"	
Brake warning lamp	BRC-87. "Description"	
VDC OFF indicator lamp	BRC-88. "Description"	
VDC warning lamp	BRC-89. "Description"	

DIAGNOSIS SYSTEM [ABS ACTUATOR AND ELECTRIC UNIT (CONTROL UNIT)]

< SYSTEM DESCRIPTION >

[VDC/TCS/ABS]

DIAGNOSIS SYSTEM [ABS ACTUATOR AND ELECTRIC UNIT (CONTROL UNIT)]

CONSULT-III Function

INFOID:000000006450484

FUNCTION

CONSULT-III can display each diagnostic item using the diagnostic test modes shown following.

Diagnostic test mode	Function
Work support	This mode enables a technician to adjust some devices faster and more accurately by following the indications on CONSULT-III.
Self-diagnostic result	Self-diagnostic results can be read and erased quickly.
Data monitor	Input/Output data in the ABS actuator and electric unit (control unit) can be read.
Active test	Diagnostic test mode is which CONSULT-III drives some actuators apart from the ABS actuator and electric unit (control unit) and also shifts some parameters in a specified range.
ECU identification	ABS actuator and electric unit (control unit) part number can be read.

WORK SUPPORT

Item	Description
ST ANGLE SENSOR ADJUSTMENT	Adjusts the neutral position of the steering angle sensor.

SELF-DIAGNOSTIC RESULT

Operation Procedure

Before performing the self-diagnosis for "ABS" with CONSULT-III, start engine and drive vehicle at 30 km/h (19 MPH) or more for approximately 1 minute.

Display Item List

Refer to [BRC-102, "DTC No. Index"](#).

How to Erase Self-diagnosis Results

After erasing DTC memory for "ABS" with CONSULT-III, start engine and drive vehicle at 30 km/h (19 MPH) or more for approximately 1 minute as the final inspection, and make sure that the ABS warning lamp, VDC warning lamp and brake warning lamp turn OFF.

CAUTION:

If memory cannot be erased, perform applicable diagnosis.

NOTE:

- When the wheel sensor malfunctions, after inspecting the wheel sensor system, ABS warning lamp, VDC warning lamp and brake warning lamp will not turn OFF even when the system is normal unless the vehicle is driving at approximately 30 km/h (19 MPH) or more for approximately 1 minute.
- Brake warning lamp will turn ON in case of parking brake operation (when switch is ON) or in case of brake fluid level switch operation (when brake fluid is insufficient).
- VDC OFF switch should not stay in "ON" position.

DATA MONITOR MODE

Display Item List

DIAGNOSIS SYSTEM [ABS ACTUATOR AND ELECTRIC UNIT (CONTROL UNIT)]

< SYSTEM DESCRIPTION >

[VDC/TCS/ABS]

×: Applicable ▼: Optional item

Monitor item (Unit)	SELECT MONITOR ITEM		Remarks
	ECU INPUT SIGNALS	MAIN SIGNALS	
FR LH SENSOR [km/h (MPH)]	×	×	Wheel speed
FR RH SENSOR [km/h (MPH)]	×	×	
RR LH SENSOR [km/h (MPH)]	×	×	
RR RH SENSOR [km/h (MPH)]	×	×	
STOP LAMP SW (On/Off)	×	×	Stop lamp switch signal status
BATTERY VOLT (V)	×	×	Battery voltage supplied to the ABS actuator and electric unit (control unit)
GEAR	×	×	Gear position determined by TCM
SLCT LVR POSI	×	×	A/T selector lever position
OFF SW (On/Off)	×	×	VDC OFF switch
YAW RATE SEN (d/s)	×	×	Yaw rate detected by yaw rate/side G sensor
4WD MODE MON	×	×	AWD activated (only AWD models)
ACCEL POS SIG (%)	×	▼	Throttle actuator opening/closing is displayed (Linked with accelerator pedal)
SIDE G-SENSOR (m/s ²)	×	▼	Transverse G detected by yaw rate/side G sensor
STR ANGLE SIG (°)	×	▼	Steering angle detected by steering angle sensor
PRESS SENSOR (bar)	×	▼	Brake fluid pressure detected by pressure sensor
ENGINE RPM [tr/min (rpm)]	×	▼	Engine speed
FLUID LEV SW (On/Off)	×	▼	Brake fluid level switch signal status
PARK BRAKE SW (On/Off)	×	▼	Parking brake switch signal status
FR RH IN SOL (On/Off)	▼	×	Operation status of each solenoid valve
FR RH OUT SOL (On/Off)	▼	×	
FR LH IN SOL (On/Off)	▼	×	
FR LH OUT SOL (On/Off)	▼	×	
RR RH IN SOL (On/Off)	▼	×	
RR RH OUT SOL (On/Off)	▼	×	
RR LH IN SOL (On/Off)	▼	×	
RR LH OUT SOL (On/Off)	▼	×	

DIAGNOSIS SYSTEM [ABS ACTUATOR AND ELECTRIC UNIT (CONTROL UNIT)]

< SYSTEM DESCRIPTION >

[VDC/TCS/ABS]

Monitor item (Unit)	SELECT MONITOR ITEM		Remarks	
	ECU INPUT SIGNALS	MAIN SIGNALS		
MOTOR RELAY (On/Off)	▼	×	Motor and motor relay operation	A
ACTUATOR RLY (On/Off)	▼	×	Actuator relay operation	B
ABS WARN LAMP (On/Off)	▼	×	ABS warning lamp	C
OFF LAMP (On/Off)	▼	×	VDC OFF indicator lamp	D
SLIP/VDC LAMP (On/Off)	▼	×	VDC warning lamp	E
BST OPER SIG	▼	▼	Not applied but displayed.	E
EBD SIGNAL (On/Off)	▼	▼	EBD operation	BRC
ABS SIGNAL (On/Off)	▼	▼	ABS operation	
TCS SIGNAL (On/Off)	▼	▼	TCS operation	G
VDC SIGNAL (On/Off)	▼	▼	VDC operation	
EBD FAIL SIG (On/Off)	▼	▼	EBD fail-safe signal	H
ABS FAIL SIG (On/Off)	▼	▼	ABS fail-safe signal	I
TCS FAIL SIG (On/Off)	▼	▼	TCS fail-safe signal	
VDC FAIL SIG (On/Off)	▼	▼	VDC fail-safe signal	J
CRANKING SIG (On/Off)	▼	▼	Crank operation	K
USV [FR-RL] (On/Off)	▼	▼	VDC switch-over valve	
USV [FL-RR] (On/Off)	▼	▼		L
HSV [FR-RL] (On/Off)	▼	▼		M
HSV [FL-RR] (On/Off)	▼	▼		
V/R OUTPUT (On/Off)	▼	▼	Solenoid valve relay activated	N
M/R OUTPUT (On/Off)	▼	▼	Actuator motor and motor relay activated	O

ACTIVE TEST MODE

CAUTION:

- Do not perform active test while driving vehicle.
- Make sure to completely bleed air from brake system.
- The active test cannot be performed with the ABS warning lamp, VDC warning lamp and brake warning lamp are ON.
- ABS warning lamp, VDC warning lamp and brake warning lamp are ON during active test.

NOTE:

- When active test is performed while depressing the pedal, the pedal depression amount will change. This is normal. (Only solenoid valve and ABS motor.)

DIAGNOSIS SYSTEM [ABS ACTUATOR AND ELECTRIC UNIT (CONTROL UNIT)]

< SYSTEM DESCRIPTION >

[VDC/TCS/ABS]

- “TEST IS STOPPED” in “ABS” with CONSULT-III is displayed 10 seconds after operation start.
- After “TEST IS STOPPED” in “ABS” with CONSULT-III is displayed, to perform test again.

Test Item

ABS SOLENOID VALVE

- Select “Up”, “Keep” and “Down” of “ACTIVE TEST” in “ABS” with CONSULT-III. Then use screen monitor to check that solenoid valve operates as shown in the table below.

Test item	Display item (Note)	Display		
		Up	Keep	Down
FR RH SOL	FR RH IN SOL	Off	On	On
	FR RH OUT SOL	Off	Off	On*
	USV [FR-RL]	Off	Off	Off
	HSV [FR-RL]	Off	Off	Off
FR LH SOL	FR LH IN SOL	Off	On	On
	FR LH OUT SOL	Off	Off	On*
	USV [FL-RR]	Off	Off	Off
	HSV [FL-RR]	Off	Off	Off
RR RH SOL	RR RH IN SOL	Off	On	On
	RR RH OUT SOL	Off	Off	On*
	USV [FL-RR]	Off	Off	Off
	HSV [FL-RR]	Off	Off	Off
RR LH SOL	RR LH IN SOL	Off	On	On
	RR LH OUT SOL	Off	Off	On*
	USV [FR-RL]	Off	Off	Off
	HSV [FR-RL]	Off	Off	Off

*: On for 1 to 2 seconds after the select, and then Off.

NOTE:

A brief moment of On/Off condition occurs every 20 seconds after ignition switch turned ON. This is not malfunction because it is an operation for checking.

ABS SOLENOID VALVE (ACT)

- Select “Up”, “ACT UP” and “ACT KEEP” of “ACTIVE TEST” in “ABS” with CONSULT-III. Then use screen monitor to check that solenoid valve operates as shown in the table below.

Test item	Display item (Note)	Display		
		Up	ACT UP	ACT KEEP
FR RH ABS SOLENOID (ACT)	FR RH IN SOL	Off	Off	Off
	FR RH OUT SOL	Off	Off	Off
	USV [FR-RL]	Off	On	On
	HSV [FR-RL]	Off	On*	Off
FR LH ABS SOLENOID (ACT)	FR LH IN SOL	Off	Off	Off
	FR LH OUT SOL	Off	Off	Off
	USV [FL-RR]	Off	On	On
	HSV [FL-RR]	Off	On*	Off
RR RH ABS SOLENOID (ACT)	RR RH IN SOL	Off	Off	Off
	RR RH OUT SOL	Off	Off	Off
	USV [FL-RR]	Off	On	On
	HSV [FL-RR]	Off	On*	Off

DIAGNOSIS SYSTEM [ABS ACTUATOR AND ELECTRIC UNIT (CONTROL UNIT)]

< SYSTEM DESCRIPTION >

[VDC/TCS/ABS]

Test item	Display item (Note)	Display		
		Up	ACT UP	ACT KEEP
RR LH ABS SOLENOID (ACT)	RR LH IN SOL	Off	Off	Off
	RR LH OUT SOL	Off	Off	Off
	USV [FR-RL]	Off	On	On
	HSV [FR-RL]	Off	On*	Off

A
B
C
D
E
G
H
I
J
K
L
M
N
O
P

*: On for 1 to 2 seconds after the select, and then Off.

NOTE:

A brief moment of On/Off condition occurs every 20 seconds after ignition switch turned ON. This is not malfunction because it is an operation for checking.

ABS MOTOR

- Select "On" and "Off" of "ACTIVE TEST" in "ABS" with CONSULT-III. Make sure motor relay and actuator relay operates as shown in table below.

Test item	Display item	Display	
		On	Off
ABS MOTOR	MOTOR RELAY	On	Off
	ACTUATOR RLY (Note)	On	On

BRC

NOTE:

A brief moment of On/Off condition occurs every 20 seconds after ignition switch turned ON. This is not malfunction because it is an operation for checking.

ECU IDENTIFICATION

ABS actuator and electric unit (control unit) part number can be read.

C1101, C1102, C1103, C1104 WHEEL SENSOR

< DTC/CIRCUIT DIAGNOSIS >

[VDC/TCS/ABS]

DTC/CIRCUIT DIAGNOSIS

C1101, C1102, C1103, C1104 WHEEL SENSOR

Description

INFOID:000000006450485

When the sensor rotor rotates, the magnetic field changes. It converts the magnetic field changes to current signals (rectangular wave) and transmits them to the ABS actuator and electric unit (control unit).

DTC Logic

INFOID:000000006450486

DTC DETECTION LOGIC

DTC	Display item	Malfunction detected condition	Possible cause
C1101	RR RH SENSOR-1	Circuit of rear RH wheel sensor is open. Or when the sensor power voltage is outside the standard.	<ul style="list-style-type: none">• Harness or connector• Wheel sensor• ABS actuator and electric unit (control unit)
C1102	RR LH SENSOR-1	Circuit of rear LH wheel sensor is open. Or when the sensor power voltage is outside the standard.	
C1103	FR RH SENSOR-1	Circuit of front RH wheel sensor is open. Or when the sensor power voltage is outside the standard.	
C1104	FR LH SENSOR-1	Circuit of front LH wheel sensor is open. Or when the sensor power voltage is outside the standard.	

DTC CONFIRMATION PROCEDURE

1. DTC REPRODUCTION PROCEDURE

1. Start the engine and drive the vehicle at 30 km/h (19 MPH) or more for approximately 1 minute.
2. Perform self-diagnosis for "ABS" with CONSULT-III.

Is DTC "C1101", "C1102", "C1103" or "C1104" detected?

- YES >> Proceed to diagnosis. Refer to [BRC-32, "Diagnosis Procedure"](#).
NO >> INSPECTION END

Diagnosis Procedure

INFOID:000000006450487

CAUTION:

Never check between wheel sensor harness connector terminals.

1. CHECK WHEEL SENSOR

1. Turn the ignition switch OFF.
2. Check wheel sensor for damage.

Is the inspection result normal?

- YES >> GO TO 3.
NO >> GO TO 2.

2. REPLACE WHEEL SENSOR (1)

1. Replace wheel sensor. Refer to [BRC-115, "Exploded View"](#).
2. Erase self-diagnosis result for "ABS".
3. Turn the ignition switch OFF, and wait 10 seconds or more.
4. Start the engine.
5. Drive the vehicle at approx. 30 km/h (19 MPH) or more for approx. 1 minute.
6. Stop the vehicle.
7. Perform self-diagnosis for "ABS" with CONSULT-III.

Is DTC "C1101", "C1102", "C1103" or "C1104" detected?

- YES >> GO TO 3.
NO >> INSPECTION END

3. CHECK CONNECTOR

1. Turn the ignition switch OFF.
2. Check ABS actuator and electric unit (control unit) harness connector for disconnection or looseness.

C1101, C1102, C1103, C1104 WHEEL SENSOR

< DTC/CIRCUIT DIAGNOSIS >

[VDC/TCS/ABS]

3. Check wheel sensor harness connector for disconnection or looseness.

Is the inspection result normal?

YES >> GO TO 5.

NO >> Repair or replace error-detected parts, securely lock the connector, and GO TO 4.

4.PERFORM SELF-DIAGNOSIS (1)

1. Erase self-diagnosis result for "ABS" with CONSULT-III.
2. Turn the ignition switch OFF, and wait 10 seconds or more.
3. Start the engine.
4. Drive the vehicle at approx. 30 km/h (19 MPH) or more for approx. 1 minute.
5. Stop the vehicle.
6. Perform self-diagnosis for "ABS" with CONSULT-III.

Is DTC "C1101", "C1102", "C1103" or "C1104" detected?

YES >> GO TO 5.

NO >> INSPECTION END

5.CHECK TERMINAL

1. Turn the ignition switch OFF.
2. Disconnect ABS actuator and electric unit (control unit) harness connector and then check ABS actuator and electric unit (control unit) pin terminals for damage or loose connection with harness connector.
3. Disconnect wheel sensor harness connector and check each wheel sensor pin terminals for damage or loose connection with harness connector.

Is the inspection result normal?

YES >> GO TO 7.

NO >> Repair or replace error-detected parts and GO TO 6.

6.PERFORM SELF-DIAGNOSIS (2)

1. Connect ABS actuator and electric unit (control unit) harness connector.
2. Connect wheel sensor harness connector.
3. Erase self-diagnosis result for "ABS".
4. Turn the ignition switch OFF, and wait 10 seconds or more.
5. Start the engine.
6. Drive the vehicle at approx. 30 km/h (19 MPH) or more for approx. 1 minute.
7. Stop the vehicle.
8. Perform self-diagnosis for "ABS" with CONSULT-III.

Is DTC "C1101", "C1102", "C1103" or "C1104" detected?

YES >> GO TO 7.

NO >> INSPECTION END

7.CHECK WHEEL SENSOR HARNESS

1. Turn the ignition switch OFF.
2. Disconnect ABS actuator and electric unit (control unit) harness connector.
3. Disconnect wheel sensor harness connector.
4. Check continuity between ABS actuator and electric unit (control unit) harness connector and wheel sensor harness connector. (Check continuity when steering wheel is steered to RH and LH, or center harness in wheel housing is moved.)

Measurement connector and terminal for power supply circuit

ABS actuator and electric unit (control unit)		Wheel sensor		Continuity
Connector	Terminal	Connector	Terminal	
E41	26	E60 (Front LH wheel)	1	Existed
	9	E27 (Front RH wheel)		
	6	B34 (Rear LH wheel)		
	7	B33 (Rear RH wheel)		

C1101, C1102, C1103, C1104 WHEEL SENSOR

[VDC/TCS/ABS]

< DTC/CIRCUIT DIAGNOSIS >

Measurement connector and terminal for signal circuit

ABS actuator and electric unit (control unit)		Wheel sensor		Continuity
Connector	Terminal	Connector	Terminal	
E41	5	E60 (Front LH wheel)	2	Existed
	10	E27 (Front RH wheel)		
	27	B34 (Rear LH wheel)		
	29	B33 (Rear RH wheel)		

Is the inspection result normal?

YES >> GO TO 9.

NO >> Repair or replace error-detected parts and GO TO 8.

8.PERFORM SELF-DIAGNOSIS (3)

1. Connect ABS actuator and electric unit (control unit) harness connector.
2. Connect wheel sensor harness connector.
3. Erase self-diagnosis result for "ABS".
4. Turn the ignition switch OFF, and wait 10 seconds or more.
5. Start the engine.
6. Drive the vehicle at approx. 30 km/h (19 MPH) or more for approx. 1 minute.
7. Stop the vehicle.
8. Perform self-diagnosis for "ABS" with CONSULT-III.

Is DTC "C1101", "C1102", "C1103" or "C1104" detected?

YES >> GO TO 9.

NO >> INSPECTION END

9.REPLACE WHEEL SENSOR (2)

1. Replace wheel sensor. Refer to [BRC-115, "Exploded View"](#).
2. Erase self-diagnosis result for "ABS" with CONSULT-III.
3. Turn the ignition switch OFF, and wait 10 seconds or more.
4. Start the engine.
5. Drive the vehicle at approx. 30 km/h (19 MPH) or more for approx. 1 minute.
6. Stop the vehicle.
7. Perform self-diagnosis for "ABS" with CONSULT-III.

Is DTC "C1101", "C1102", "C1103" or "C1104" detected?

YES >> Replace ABS actuator and electric unit (control unit). Refer to [BRC-118, "Exploded View"](#).

NO >> INSPECTION END

Special Repair Requirement

INFOID:000000006450488

1.ADJUSTMENT OF STEERING ANGLE SENSOR NEUTRAL POSITION

Always perform the neutral position adjustment for the steering angle sensor, when replacing the ABS actuator and electric unit (control unit). Refer to [BRC-9, "ADJUSTMENT OF STEERING ANGLE SENSOR NEUTRAL POSITION : Special Repair Requirement"](#).

>> END

C1105, C1106, C1107, C1108 WHEEL SENSOR

< DTC/CIRCUIT DIAGNOSIS >

[VDC/TCS/ABS]

C1105, C1106, C1107, C1108 WHEEL SENSOR

Description

INFOID:000000006450489

When the sensor rotor rotates, the magnetic field changes. It converts the magnetic field changes to current signals (rectangular wave) and transmits them to the ABS actuator and electric unit (control unit).

DTC Logic

INFOID:000000006450490

DTC DETECTION LOGIC

DTC	Display item	Malfunction detected condition	Possible cause
C1105	RR RH SENSOR-2	When the circuit in the rear RH wheel sensor is short-circuited. Or when the distance between the wheel sensor and sensor rotor is too large and the sensor pulse cannot be recognized by the control unit.	<ul style="list-style-type: none">• Harness or connector• Wheel sensor• ABS actuator and electric unit (control unit)
C1106	RR LH SENSOR-2	When the circuit in the rear LH wheel sensor is short-circuited. Or when the distance between the wheel sensor and sensor rotor is too large and the sensor pulse cannot be recognized by the control unit.	
C1107	FR RH SENSOR-2	When the circuit in the front RH wheel sensor is short-circuited. Or when the distance between the wheel sensor and sensor rotor is too large and the sensor pulse cannot be recognized by the control unit.	
C1108	FR LH SENSOR-2	When the circuit in the front LH wheel sensor is short-circuited. Or when the distance between the wheel sensor and sensor rotor is too large and the sensor pulse cannot be recognized by the control unit.	

DTC CONFIRMATION PROCEDURE

1. DTC REPRODUCTION PROCEDURE

1. Start the engine and drive the vehicle at 30 km/h (19 MPH) or more for approximately 1 minute.
2. Perform self-diagnosis for "ABS" with CONSULT-III.

Is DTC "C1105", "C1106", "C1107" or "C1108" detected?

- YES >> Proceed to diagnosis. Refer to [BRC-35, "Diagnosis Procedure"](#).
NO >> INSPECTION END

Diagnosis Procedure

INFOID:000000006450491

CAUTION:

Never check between wheel sensor harness connector terminals.

1. CHECK ABS ACTUATOR AND ELECTRIC UNIT (CONTROL UNIT) POWER SUPPLY SYSTEM

Check ABS actuator and electric unit (control unit) power supply system. Refer to [BRC-80, "Diagnosis Procedure"](#).

Is the inspection result normal?

- YES >> GO TO 2.
NO >> Repair or replace error-detected parts.

2. CHECK TIRE

1. Turn the ignition switch OFF.
2. Check tire air pressure, wear and size. Refer to [WT-53, "Tire Air Pressure"](#).

Is the inspection result normal?

- YES >> GO TO 5.
NO >> Adjust air pressure or replace tire and GO TO 3.

3. CHECK DATA MONITOR (1)

1. Erase self-diagnosis result for "ABS" with CONSULT-III.
2. Turn the ignition switch OFF, and wait 10 seconds or more.

C1105, C1106, C1107, C1108 WHEEL SENSOR

[VDC/TCS/ABS]

< DTC/CIRCUIT DIAGNOSIS >

3. Start the engine.
4. Select "ABS" and "DATA MONITOR", check "FR LH SENSOR", "FR RH SENSOR", "RR LH SENSOR" and "RR RH SENSOR" with CONSULT-III.

NOTE:

Set the "DATA MONITOR" recording speed to "10 msec".

5. Read a value (wheel speed) of both normal wheel sensors and error-detecting wheel sensor.

Regarding the deference at 30 km/h (19 MPH) between the wheel speed detected by the error detecting wheel sensor and the maximum/minimum wheel speed detected by the normal wheel sensors, is the difference within 5%, respectively?

YES >> GO TO 4.

NO >> GO TO 5.

4.PERFORM SELF-DIAGNOSIS (1)

1. Drive the vehicle at approx. 30 km/h (19 MPH) or more for approx. 1 minute.
2. Stop the vehicle.
3. Perform self-diagnosis for "ABS" with CONSULT-III.

Is DTC "C1105", "C1106", "C1107" or "C1108" detected?

YES >> GO TO 5.

NO >> INSPECTION END

5.CHECK WHEEL SENSOR

1. Turn the ignition switch OFF.
2. Check wheel sensor for damage.
3. Remove dust and foreign matter adhered to the sensor rotor with a vacuum dust collector through the wheel sensor mounting hole.

CAUTION:

Install wheel sensor with no backlash and float, and tighten the mounting bolt to the specified torque. Refer to [BRC-115, "Exploded View"](#).

Is the inspection result normal?

YES >> GO TO 8.

NO >> GO TO 6.

6.REPLACE WHEEL SENSOR (1)

1. Replace wheel sensor. Refer to [BRC-115, "Exploded View"](#).
2. Erase self-diagnosis result for "ABS" with CONSULT-III.
3. Turn the ignition switch OFF, and wait 10 seconds or more.
4. Start the engine.
5. Select "ABS" and "DATA MONITOR", check "FR LH SENSOR", "FR RH SENSOR", "RR LH SENSOR" and "RR RH SENSOR" with CONSULT-III.

NOTE:

Set the "DATA MONITOR" recording speed to "10 msec".

6. Read a value (wheel speed) of both normal wheel sensors and error-detecting wheel sensor.

Regarding the deference at 30 km/h (19 MPH) between the wheel speed detected by the error detecting wheel sensor and the maximum/minimum wheel speed detected by the normal wheel sensors, is the difference within 5%, respectively?

YES >> GO TO 7.

NO >> GO TO 19.

7.PERFORM SELF-DIAGNOSIS (2)

1. Drive the vehicle at approx. 30 km/h (19 MPH) or more for approx. 1 minute.
2. Stop the vehicle.
3. Perform self-diagnosis for "ABS" with CONSULT-III.

Is DTC "C1105", "C1106", "C1107" or "C1108" detected?

YES >> GO TO 19.

NO >> INSPECTION END

8.CHECK CONNECTOR

1. Turn the ignition switch OFF.
2. Check ABS actuator and electric unit (control unit) harness connector for disconnection or looseness.

C1105, C1106, C1107, C1108 WHEEL SENSOR

[VDC/TCS/ABS]

< DTC/CIRCUIT DIAGNOSIS >

3. Check wheel sensor harness connector for disconnection or looseness.

Is the inspection result normal?

YES >> GO TO 11.

NO >> Repair or replace error-detected parts, securely lock the connector, and GO TO 9.

9.CHECK DATA MONITOR (2)

1. Erase self-diagnosis result for "ABS" with CONSULT-III.
2. Turn the ignition switch OFF, and wait 10 seconds or more.
3. Start the engine.
4. Select "ABS" and "DATA MONITOR", check "FR LH SENSOR", "FR RH SENSOR", "RR LH SENSOR" and "RR RH SENSOR" with CONSULT-III.

NOTE:

Set the "DATA MONITOR" recording speed to "10 msec".

5. Read a value (wheel speed) of both normal wheel sensors and error-detecting wheel sensor.

Regarding the deference at 30 km/h (19 MPH) between the wheel speed detected by the error detecting wheel sensor and the maximum/minimum wheel speed detected by the normal wheel sensors, is the difference within 5%. respectively?

YES >> GO TO 10.

NO >> GO TO 11.

10.PERFORM SELF-DIAGNOSIS (3)

1. Drive the vehicle at approx. 30 km/h (19 MPH) or more for approx. 1 minute.
2. Stop the vehicle.
3. Perform self-diagnosis for "ABS" with CONSULT-III.

Is DTC "C1105", "C1106", "C1107" or "C1108" detected?

YES >> GO TO 11.

NO >> INSPECTION END

11.CHECK TERMINAL

1. Turn the ignition switch OFF.
2. Disconnect ABS actuator and electric unit (control unit) harness connector and then check ABS actuator and electric unit (control unit) pin terminals for damage or loose connection with harness connector.
3. Disconnect wheel sensor harness connector and check each wheel sensor pin terminals for damage or loose connection with harness connector.

Is the inspection result normal?

YES >> GO TO 14.

NO >> Repair or replace error-detected parts and GO TO 12.

12.CHECK DATA MONITOR (3)

1. Connect ABS actuator and electric unit (control unit) harness connector.
2. Connect wheel sensor harness connector.
3. Erase self-diagnosis result for "ABS" with CONSULT-III.
4. Turn the ignition switch OFF, and wait 10 seconds or more.
5. Start the engine.
6. Select "ABS" and "DATA MONITOR", check "FR LH SENSOR", "FR RH SENSOR", "RR LH SENSOR" and "RR RH SENSOR" with CONSULT-III.

NOTE:

Set the "DATA MONITOR" recording speed to "10 msec".

7. Read a value (wheel speed) of both normal wheel sensors and error-detecting wheel sensor.

Regarding the deference at 30 km/h (19 MPH) between the wheel speed detected by the error detecting wheel sensor and the maximum/minimum wheel speed detected by the normal wheel sensors, is the difference within 5%. respectively?

YES >> GO TO 13.

NO >> GO TO 14.

13.PERFORM SELF-DIAGNOSIS (4)

1. Drive the vehicle at approx. 30 km/h (19 MPH) or more for approx. 1 minute.
2. Stop the vehicle.
3. Perform self-diagnosis for "ABS" with CONSULT-III.

C1105, C1106, C1107, C1108 WHEEL SENSOR

[VDC/TCS/ABS]

< DTC/CIRCUIT DIAGNOSIS >

Is DTC "C1105", "C1106", "C1107" or "C1108" detected?

YES >> GO TO 14.

NO >> INSPECTION END

14. CHECK WHEEL SENSOR HARNESS

1. Turn the ignition switch OFF.
2. Disconnect ABS actuator and electric unit (control unit) harness connector.
3. Disconnect wheel sensor harness connector.
4. Check continuity between ABS actuator and electric unit (control unit) harness connector and the ground.

ABS actuator and electric unit (control unit)		—	Continuity
Connector	Terminal		
E41	5, 26	Ground	Not existed
	9, 10		
	6, 27		
	7, 29		

Is the inspection result normal?

YES >> GO TO 15.

NO >> Repair or replace error-detected parts and GO TO 15.

15. CHECK DATA MONITOR (4)

1. Connect ABS actuator and electric unit (control unit) harness connector.
2. Connect wheel sensor harness connector.
3. Erase self-diagnosis result for "ABS" with CONSULT-III.
4. Turn the ignition switch OFF, and wait 10 seconds or more.
5. Start the engine.
6. Select "ABS" and "DATA MONITOR", check "FR LH SENSOR", "FR RH SENSOR", "RR LH SENSOR" and "RR RH SENSOR" with CONSULT-III.

NOTE:

Set the "DATA MONITOR" recording speed to "10 msec".

7. Read a value (wheel speed) of both normal wheel sensors and error-detecting wheel sensor.

Regarding the deference at 30 km/h (19 MPH) between the wheel speed detected by the error detecting wheel sensor and the maximum/minimum wheel speed detected by the normal wheel sensors, is the difference within 5%, respectively?

YES >> GO TO 16.

NO >> GO TO 17.

16. PERFORM SELF-DIAGNOSIS (5)

1. Drive the vehicle at approx. 30 km/h (19 MPH) or more for approx. 1 minute.
2. Stop the vehicle.
3. Perform self-diagnosis for "ABS" with CONSULT-III.

Is DTC "C1105", "C1106", "C1107" or "C1108" detected?

YES >> GO TO 17.

NO >> INSPECTION END

17. REPLACE WHEEL SENSOR (2)

1. Replace wheel sensor. Refer to [BRC-115, "Exploded View"](#).
2. Erase self-diagnosis result for "ABS" with CONSULT-III.
3. Turn the ignition switch OFF, and wait 10 seconds or more.
4. Start the engine.
5. Select "ABS" and "DATA MONITOR", check "FR LH SENSOR", "FR RH SENSOR", "RR LH SENSOR" and "RR RH SENSOR" with CONSULT-III.

NOTE:

Set the "DATA MONITOR" recording speed to "10 msec".

6. Read a value (wheel speed) of both normal wheel sensors and error-detecting wheel sensor.

C1105, C1106, C1107, C1108 WHEEL SENSOR

[VDC/TCS/ABS]

< DTC/CIRCUIT DIAGNOSIS >

Regarding the deference at 30 km/h (19 MPH) between the wheel speed detected by the error detecting wheel sensor and the maximum/minimum wheel speed detected by the normal wheel sensors, is the difference within 5%. respectively?

- YES >> GO TO 18.
- NO >> GO TO 19.

18.PERFORM SELF-DIAGNOSIS (6)

1. Drive the vehicle at approx. 30 km/h (19 MPH) or more for approx. 1 minute.
2. Stop the vehicle.
3. Perform self-diagnosis for "ABS" with CONSULT-III.

Is DTC "C1105", "C1106", "C1107" or "C1108" detected?

- YES >> GO TO 19.
- NO >> INSPECTION END

19.REPLACE SENSOR ROTOR

1. Replace sensor rotor.
 - Front: Refer to [BRC-116. "FRONT SENSOR ROTOR : Exploded View"](#).
 - Rear: Refer to [BRC-116. "REAR SENSOR ROTOR : Exploded View"](#).
2. Erase self-diagnosis result for "ABS" with CONSULT-III.
3. Turn the ignition switch OFF, and wait 10 seconds or more.
4. Start the engine.
5. Drive the vehicle at approx. 30 km/h (19 MPH) or more for approx. 1 minute.
6. Stop the vehicle.
7. Perform self-diagnosis for "ABS" with CONSULT-III.

Is DTC "C1105", "C1106", "C1107" or "C1108" detected?

- YES >> Replace ABS actuator and electric unit (control unit). Refer to [BRC-118. "Exploded View"](#).
- NO >> INSPECTION END

Special Repair Requirement

INFOID:000000006450492

1.ADJUSTMENT OF STEERING ANGLE SENSOR NEUTRAL POSITION

Always perform the neutral position adjustment for the steering angle sensor, when replacing the ABS actuator and electric unit (control unit). Refer to [BRC-9, "ADJUSTMENT OF STEERING ANGLE SENSOR NEUTRAL POSITION : Special Repair Requirement"](#).

>> END

C1109 POWER AND GROUND SYSTEM

< DTC/CIRCUIT DIAGNOSIS >

[VDC/TCS/ABS]

C1109 POWER AND GROUND SYSTEM

Description

INFOID:000000006450493

Supplies electric power to the ABS actuator and electric unit (control unit).

DTC Logic

INFOID:000000006450494

DTC DETECTION LOGIC

DTC	Display item	Malfunction detected condition	Possible cause
C1109	BATTERY VOLTAGE [ABNORMAL]	When the ABS actuator and electric unit (control unit) power supply voltage is lower than normal.	<ul style="list-style-type: none"> • Harness or connector • ABS actuator and electric unit (control unit)

DTC CONFIRMATION PROCEDURE

1. DTC REPRODUCTION PROCEDURE

1. Turn the ignition switch OFF to ON.
2. Perform self-diagnosis for "ABS" with CONSULT-III.

Is DTC "C1109" detected?

- YES >> Proceed to diagnosis procedure. Refer to [BRC-40, "Diagnosis Procedure"](#).
 NO >> INSPECTION END

Diagnosis Procedure

INFOID:000000006450495

1. CHECK CONNECTOR

1. Turn the ignition switch OFF.
2. Disconnect ABS actuator and electric unit (control unit) harness connector.
3. Check terminal for deformation, disconnection, looseness, etc.

Is the inspection result normal?

- YES >> GO TO 2.
 NO >> Repair or replace error-detected parts.

2. CHECK ABS ACTUATOR AND ELECTRIC UNIT (CONTROL UNIT) POWER SUPPLY

1. Check the voltage between ABS actuator and electric unit (control unit) harness connector and ground.

ABS actuator and electric unit (control unit)		—	Condition	Voltage
Connector	Terminal			
E41	28	Ground	Ignition switch: OFF	Approx. 0 V

2. Turn the ignition switch ON.

CAUTION:

Never start the engine.

3. Check the voltage between ABS actuator and electric unit (control unit) harness connector and ground.

ABS actuator and electric unit (control unit)		—	Condition	Voltage
Connector	Terminal			
E41	28	Ground	Ignition switch: ON	Battery voltage

Is the inspection result normal?

- YES >> GO TO 4.
 NO >> GO TO 3.

3. CHECK ABS ACTUATOR AND ELECTRIC UNIT (CONTROL UNIT) POWER SUPPLY CIRCUIT

1. Turn the ignition switch OFF.
2. Check 10A fusible link (45).
3. Disconnect IPDM E/R harness connector.

C1109 POWER AND GROUND SYSTEM

[VDC/TCS/ABS]

< DTC/CIRCUIT DIAGNOSIS >

4. Check continuity between ABS actuator and electric unit (control unit) harness connector and IPDM E/R harness connector.

ABS actuator and electric unit (control unit)		IPDM E/R		Continuity
Connector	Terminal	Connector	Terminal	
E41	28	E5	25	Existed

Is the inspection result normal?

YES >> Perform the trouble diagnosis for ignition power supply circuit. Refer to [PG-67. "Wiring Diagram - IGNITION POWER SUPPLY -"](#).

NO >> Repair or replace error-detected parts.

4.CHECK ABS ACTUATOR AND ELECTRIC UNIT (CONTROL UNIT) GROUND CIRCUIT

Check the continuity between ABS actuator and electric unit (control unit) harness connector and ground.

ABS actuator and electric unit (control unit)		—	Continuity
Connector	Terminal		
E41	1	Ground	Existed
	4		

Is the inspection result normal?

YES >> Replace ABS actuator and electric unit (control unit).

NO >> Repair or replace error-detected parts. (Check ABS earth bolt for tightness and corrosion.)

Special Repair Requirement

INFOID:000000006450496

1.AJUSTMENT OF STEERING ANGLE SENSOR NEUTRAL POSITION

Always perform the neutral position adjustment for the steering angle sensor, when replacing the ABS actuator and electric unit (control unit). Refer to [BRC-9. "ADJUSTMENT OF STEERING ANGLE SENSOR NEUTRAL POSITION : Special Repair Requirement"](#).

>> END

C1110, C1153, C1170 ABS ACTUATOR AND ELECTRIC UNIT (CONTROL UNIT)

DTC Logic

INFOID:000000006450497

DTC DETECTION LOGIC

DTC	Display item	Malfunction detected condition	Possible cause
C1110	CONTROLLER FAILURE	When there is an internal malfunction in the ABS actuator and electric unit (control unit).	ABS actuator and electric unit (control unit)
C1153	EMERGENCY BRAKE	When ABS actuator and electric unit (control unit) is malfunctioning. (Pressure increase is too much or too little)	
C1170	VARIANT CODING	In a case where VARIANT CODING is different.	

DTC CONFIRMATION PROCEDURE

1.DTC REPRODUCTION PROCEDURE

1. Turn the ignition switch ON.
2. Perform self-diagnosis for "ABS" with CONSULT-III.

Is DTC "C1110", "C1153" or "C1170" detected?

- YES >> Proceed to diagnosis procedure. Refer to [BRC-42, "Diagnosis Procedure"](#).
 NO >> INSPECTION END

Diagnosis Procedure

INFOID:000000006450498

1.REPLACE ABS ACTUATOR AND ELECTRIC UNIT (CONTROL UNIT)

CAUTION:

Replace ABS actuator and electric unit (control unit) when self-diagnostic result shows items other than those applicable.

>> Replace ABS actuator and electric unit (control unit).

Special Repair Requirement

INFOID:000000006450499

1.ADJUSTMENT OF STEERING ANGLE SENSOR NEUTRAL POSITION

Always perform the neutral position adjustment for the steering angle sensor, when replacing the ABS actuator and electric unit (control unit). Refer to [BRC-9, "ADJUSTMENT OF STEERING ANGLE SENSOR NEUTRAL POSITION : Special Repair Requirement"](#).

>> END

C1111 ABS MOTOR, MOTOR RELAY SYSTEM

< DTC/CIRCUIT DIAGNOSIS >

[VDC/TCS/ABS]

C1111 ABS MOTOR, MOTOR RELAY SYSTEM

Description

INFOID:000000006450500

PUMP

The pump returns the brake fluid stored in the reservoir to the master cylinder by reducing the pressure.

MOTOR

The motor drives the pump according to the signals transmitted by the ABS actuator and electric unit (control unit).

MOTOR RELAY

Activates or deactivates motor according to the signals transmitted by the ABS actuator and electric unit (control unit).

DTC Logic

INFOID:000000006450501

DTC DETECTION LOGIC

DTC	Display item	Malfunction detected condition	Possible cause
C1111	PUMP MOTOR	During the actuator motor operating with ON, when the actuator motor turns OFF, or when the control line for actuator motor relay is open.	<ul style="list-style-type: none"> Harness or connector ABS actuator and electric unit (control unit)
		During the actuator motor operating with OFF, when the actuator motor turns ON, or when the control line for relay is shorted to ground.	

DTC CONFIRMATION PROCEDURE

1. DTC REPRODUCTION PROCEDURE

- Turn the ignition switch ON.
- Perform self-diagnosis for "ABS" with CONSULT-III.

Is DTC "C1111" detected?

- YES >> Proceed to diagnosis procedure. Refer to [BRC-43, "Diagnosis Procedure"](#).
 NO >> INSPECTION END

Diagnosis Procedure

INFOID:000000006450502

1. CHECK CONNECTOR

- Turn the ignition switch OFF.
- Disconnect ABS actuator and electric unit (control unit) connector.
- Check terminal for deformation, disconnect, looseness, etc.

Is the inspection result normal?

- YES >> GO TO 2.
 NO >> Repair or replace error-detected parts.

2. CHECK ABS MOTOR AND MOTOR RELAY POWER SUPPLY CIRCUIT

- Check the 50A fusible link (M).
- Check the voltage between the ABS actuator and electric unit (control unit) harness connector and ground.

ABS actuator and electric unit (control unit)		—	Voltage
Connector	Terminal		
E41	2	Ground	Battery voltage

Is the inspection result normal?

- YES >> GO TO 3.
 NO >> Perform the trouble diagnosis for battery power supply circuit. Refer to [PG-6, "Wiring Diagram - BATTERY POWER SUPPLY -"](#).

C1111 ABS MOTOR, MOTOR RELAY SYSTEM

< DTC/CIRCUIT DIAGNOSIS >

[VDC/TCS/ABS]

3. CHECK ABS ACTUATOR AND ELECTRIC UNIT (CONTROL UNIT) GROUND CIRCUIT

Check the continuity between ABS actuator and electric unit (control unit) harness connector and ground.

ABS actuator and electric unit (control unit)		—	Continuity
Connector	Terminal		
E41	1	Ground	Existed
	4		

Is the inspection result normal?

YES >> Replace ABS actuator and electric unit (control unit).

NO >> Repair or replace error-detected parts.

Special Repair Requirement

INFOID:000000006450503

1. ADJUSTMENT OF STEERING ANGLE SENSOR NEUTRAL POSITION

Always perform the neutral position adjustment for the steering angle sensor, when replacing the ABS actuator and electric unit (control unit). Refer to [BRC-9. "ADJUSTMENT OF STEERING ANGLE SENSOR NEUTRAL POSITION : Special Repair Requirement"](#).

>> END

C1115 WHEEL SENSOR

< DTC/CIRCUIT DIAGNOSIS >

[VDC/TCS/ABS]

C1115 WHEEL SENSOR

Description

INFOID:000000006450508

When the sensor rotor rotates, the magnetic field changes. It converts the magnetic field changes to current signals (rectangular wave) and transmits them to the ABS actuator and electric unit (control unit).

DTC Logic

INFOID:000000006450509

DTC DETECTION LOGIC

DTC	Display item	Malfunction detected condition	Possible cause
C1115	ABS SENSOR [ABNORMAL SIGNAL]	When wheel sensor input signal is malfunctioning.	<ul style="list-style-type: none">• Harness or connector• Wheel sensor• ABS actuator and electric unit (control unit)

DTC CONFIRMATION PROCEDURE

1. DTC REPRODUCTION PROCEDURE

1. Start the engine and drive the vehicle at 30 km/h (19 MPH) or more for approximately 1 minute.
2. Perform self-diagnosis for "ABS" with CONSULT-III.

Is DTC "C1115" detected?

- YES >> Proceed to diagnosis. Refer to [BRC-45. "Diagnosis Procedure"](#).
NO >> INSPECTION END

Diagnosis Procedure

INFOID:000000006450510

CAUTION:

For wheel sensor, never check between terminals.

1. CHECK ABS ACTUATOR AND ELECTRIC UNIT (CONTROL UNIT) POWER SUPPLY SYSTEM

Check ABS actuator and electric unit (control unit) power supply system. Refer to [BRC-80. "Diagnosis Procedure"](#).

Is the inspection result normal?

- YES >> GO TO 2.
NO >> Repair or replace error-detected parts.

2. CHECK TIRE

1. Turn the ignition switch OFF.
2. Check tire air pressure, wear and size. Refer to [WT-53. "Tire Air Pressure"](#).

Is the inspection result normal?

- YES >> GO TO 5.
NO >> Adjust air pressure or replace tire and GO TO 3.

3. CHECK DATA MONITOR (1)

1. Erase self-diagnosis result for "ABS" with CONSULT-III.
2. Turn the ignition switch OFF, and wait 10 seconds or more.
3. Start the engine.
4. Select "ABS" and "DATA MONITOR", check "FR LH SENSOR", "FR RH SENSOR", "RR LH SENSOR" and "RR RH SENSOR" with CONSULT-III.

NOTE:

Set the "DATA MONITOR" recording speed to "10 msec".

5. Read a value (wheel speed) of both normal wheel sensors and error-detecting wheel sensor.

Regarding the deference at 30 km/h (19 MPH) between the wheel speed detected by the error detecting wheel sensor and the maximum/minimum wheel speed detected by the normal wheel sensors, is the difference within 5%, respectively?

- YES >> GO TO 4.
NO >> GO TO 5.

C1115 WHEEL SENSOR

[VDC/TCS/ABS]

< DTC/CIRCUIT DIAGNOSIS >

4.PERFORM SELF-DIAGNOSIS (1)

1. Drive the vehicle at approx. 30 km/h (19 MPH) or more for approx. 1 minute.
2. Stop the vehicle.
3. Perform self-diagnosis for "ABS" with CONSULT-III.

Is DTC "C1115" detected?

YES >> GO TO 5.

NO >> INSPECTION END

5.CHECK WHEEL SENSOR

1. Turn the ignition switch OFF.
2. Check wheel sensor for damage.
3. Remove dust and foreign matter adhered to the sensor rotor with a vacuum dust collector through the wheel sensor mounting hole.

CAUTION:

Install wheel sensor with no backlash and float, and tighten the mounting bolt to the specified torque. Refer to [BRC-115, "Exploded View"](#).

Is the inspection result normal?

YES >> GO TO 8.

NO >> GO TO 6.

6.REPLACE WHEEL SENSOR (1)

1. Replace wheel sensor. Refer to [BRC-115, "Exploded View"](#).
2. Erase self-diagnosis result for "ABS" with CONSULT-III.
3. Turn the ignition switch OFF, and wait 10 seconds or more.
4. Start the engine.
5. Select "ABS" and "DATA MONITOR", check "FR LH SENSOR", "FR RH SENSOR", "RR LH SENSOR" and "RR RH SENSOR" with CONSULT-III.

NOTE:

Set the "DATA MONITOR" recording speed to "10 msec".

6. Read a value (wheel speed) of both normal wheel sensors and error-detecting wheel sensor.

Regarding the deference at 30 km/h (19 MPH) between the wheel speed detected by the error detecting wheel sensor and the maximum/minimum wheel speed detected by the normal wheel sensors, is the difference within 5%, respectively?

YES >> GO TO 7.

NO >> GO TO 19.

7.PERFORM SELF-DIAGNOSIS (2)

1. Drive the vehicle at approx. 30 km/h (19 MPH) or more for approx. 1 minute.
2. Stop the vehicle.
3. Perform self-diagnosis for "ABS" with CONSULT-III.

Is DTC "C1115" detected?

YES >> GO TO 19.

NO >> INSPECTION END

8.CHECK CONNECTOR

1. Turn the ignition switch OFF.
2. Check ABS actuator and electric unit (control unit) harness connector for disconnection or looseness.
3. Check wheel sensor harness connector for disconnection or looseness.

Is the inspection result normal?

YES >> GO TO 11.

NO >> Repair or replace error-detected parts, securely lock the connector, and GO TO 9.

9.CHECK DATA MONITOR (2)

1. Erase self-diagnosis result for "ABS" with CONSULT-III.
2. Turn the ignition switch OFF, and wait 10 seconds or more.
3. Start the engine.
4. Select "ABS" and "DATA MONITOR", check "FR LH SENSOR", "FR RH SENSOR", "RR LH SENSOR" and "RR RH SENSOR" with CONSULT-III.

C1115 WHEEL SENSOR

[VDC/TCS/ABS]

< DTC/CIRCUIT DIAGNOSIS >

NOTE:

Set the "DATA MONITOR" recording speed to "10 msec".

5. Read a value (wheel speed) of both normal wheel sensors and error-detecting wheel sensor.

Regarding the deference at 30 km/h (19 MPH) between the wheel speed detected by the error detecting wheel sensor and the maximum/minimum wheel speed detected by the normal wheel sensors, is the difference within 5%, respectively?

YES >> GO TO 10.

NO >> GO TO 11.

10.PERFORM SELF-DIAGNOSIS (3)

1. Drive the vehicle at approx. 30 km/h (19 MPH) or more for approx. 1 minute.
2. Stop the vehicle.
3. Perform self-diagnosis for "ABS" with CONSULT-III.

Is DTC "C1115" detected?

YES >> GO TO 11.

NO >> INSPECTION END

11.CHECK TERMINAL

1. Turn the ignition switch OFF.
2. Disconnect ABS actuator and electric unit (control unit) harness connector and then check ABS actuator and electric unit (control unit) pin terminals for damage or loose connection with harness connector.
3. Disconnect wheel sensor harness connector and check each wheel sensor pin terminals for damage or loose connection with harness connector.

Is the inspection result normal?

YES >> GO TO 14.

NO >> Repair or replace error-detected parts and GO TO 12.

12.CHECK DATA MONITOR (3)

1. Connect ABS actuator and electric unit (control unit) harness connector.
2. Connect wheel sensor harness connector.
3. Erase self-diagnosis result for "ABS" with CONSULT-III.
4. Turn the ignition switch OFF, and wait 10 seconds or more.
5. Start the engine.
6. Select "ABS" and "DATA MONITOR", check "FR LH SENSOR", "FR RH SENSOR", "RR LH SENSOR" and "RR RH SENSOR" with CONSULT-III.

NOTE:

Set the "DATA MONITOR" recording speed to "10 msec".

7. Read a value (wheel speed) of both normal wheel sensors and error-detecting wheel sensor.

Regarding the deference at 30 km/h (19 MPH) between the wheel speed detected by the error detecting wheel sensor and the maximum/minimum wheel speed detected by the normal wheel sensors, is the difference within 5%, respectively?

YES >> GO TO 13.

NO >> GO TO 14.

13.PERFORM SELF-DIAGNOSIS (4)

1. Drive the vehicle at approx. 30 km/h (19 MPH) or more for approx. 1 minute.
2. Stop the vehicle.
3. Perform self-diagnosis for "ABS" with CONSULT-III.

Is DTC "C1115" detected?

YES >> GO TO 14.

NO >> INSPECTION END

14.CHECK WHEEL SENSOR HARNESS

1. Turn the ignition switch OFF.
2. Disconnect ABS actuator and electric unit (control unit) harness connector.
3. Disconnect wheel sensor harness connector.
4. Check continuity between ABS actuator and electric unit (control unit) harness connector and wheel sensor harness connector. (Check continuity when steering wheel is steered to RH and LH, or center harness in wheel housing is moved.)

C1115 WHEEL SENSOR

[VDC/TCS/ABS]

< DTC/CIRCUIT DIAGNOSIS >

Measurement connector and terminal for power supply circuit

ABS actuator and electric unit (control unit)		Wheel sensor		Continuity
Connector	Terminal	Connector	Terminal	
E41	5	E60 (Front LH wheel)	2	Existed
	10	E27 (Front RH wheel)		
	27	B34 (Rear LH wheel)		
	29	B33 (Rear RH wheel)		

Measurement connector and terminal for signal circuit

ABS actuator and electric unit (control unit)		Wheel sensor		Continuity
Connector	Terminal	Connector	Terminal	
E41	26	E60 (Front LH wheel)	1	Existed
	9	E27 (Front RH wheel)		
	6	B34 (Rear LH wheel)		
	7	B33 (Rear RH wheel)		

5. Check continuity between ABS actuator and electric unit (control unit) harness connector and the ground.

ABS actuator and electric unit (control unit)		—	Continuity
Connector	Terminal		
E41	5, 26	Ground	Not existed
	9, 10		
	6, 27		
	7, 29		

Is the inspection result normal?

YES >> GO TO 15.

NO >> Repair or replace error-detected parts and GO TO 15.

15. CHECK DATA MONITOR (4)

1. Connect ABS actuator and electric unit (control unit) harness connector.
2. Connect wheel sensor harness connector.
3. Erase self-diagnosis result for "ABS" with CONSULT-III.
4. Turn the ignition switch OFF, and wait 10 seconds or more.
5. Start the engine.
6. Select "ABS" and "DATA MONITOR", check "FR LH SENSOR", "FR RH SENSOR", "RR LH SENSOR" and "RR RH SENSOR" with CONSULT-III.

NOTE:

Set the "DATA MONITOR" recording speed to "10 msec".

7. Read a value (wheel speed) of both normal wheel sensors and error-detecting wheel sensor.

Regarding the deference at 30 km/h (19 MPH) between the wheel speed detected by the error detecting wheel sensor and the maximum/minimum wheel speed detected by the normal wheel sensors, is the difference within 5%, respectively?

YES >> GO TO 16.

NO >> GO TO 17.

16. PERFORM SELF-DIAGNOSIS (5)

1. Drive the vehicle at approx. 30 km/h (19 MPH) or more for approx. 1 minute.
2. Stop the vehicle.
3. Perform self-diagnosis for "ABS" with CONSULT-III.

Is DTC "C1115" detected?

YES >> GO TO 17.

NO >> INSPECTION END

17. REPLACE WHEEL SENSOR (2)

C1115 WHEEL SENSOR

[VDC/TCS/ABS]

< DTC/CIRCUIT DIAGNOSIS >

1. Replace wheel sensor. Refer to [BRC-115. "Exploded View"](#).
2. Erase self-diagnosis result for "ABS" with CONSULT-III.
3. Turn the ignition switch OFF, and wait 10 seconds or more.
4. Start the engine.
5. Select "ABS" and "DATA MONITOR", check "FR LH SENSOR", "FR RH SENSOR", "RR LH SENSOR" and "RR RH SENSOR" with CONSULT-III.

NOTE:

Set the "DATA MONITOR" recording speed to "10 msec".

6. Read a value (wheel speed) of both normal wheel sensors and error-detecting wheel sensor.

Regarding the deference at 30 km/h (19 MPH) between the wheel speed detected by the error detecting wheel sensor and the maximum/minimum wheel speed detected by the normal wheel sensors, is the difference within 5%, respectively?

YES >> GO TO 18.

NO >> GO TO 19.

18.PERFORM SELF-DIAGNOSIS (6)

1. Drive the vehicle at approx. 30 km/h (19 MPH) or more for approx. 1 minute.
2. Stop the vehicle.
3. Perform self-diagnosis for "ABS" with CONSULT-III.

Is DTC "C1115" detected?

YES >> GO TO 19.

NO >> INSPECTION END

19.REPLACE SENSOR ROTOR

1. Replace sensor rotor.
 - Front: Refer to [BRC-116. "FRONT SENSOR ROTOR : Exploded View"](#).
 - Rear: Refer to [BRC-116. "REAR SENSOR ROTOR : Exploded View"](#).
2. Erase self-diagnosis result for "ABS".
3. Turn the ignition switch OFF, and wait 10 seconds or more.
4. Start the engine.
5. Drive the vehicle at approx. 30 km/h (19 MPH) or more for approx. 1 minute.
6. Stop the vehicle.
7. Perform self-diagnosis for "ABS" with CONSULT-III.

Is DTC "C1115" detected?

YES >> Replace ABS actuator and electric unit (control unit). Refer to [BRC-118. "Exploded View"](#).

NO >> INSPECTION END

Special Repair Requirement

INFOID:000000006450511

1.ADJUSTMENT OF STEERING ANGLE SENSOR NEUTRAL POSITION

Always perform the neutral position adjustment for the steering angle sensor, when replacing the ABS actuator and electric unit (control unit). Refer to [BRC-9. "ADJUSTMENT OF STEERING ANGLE SENSOR NEUTRAL POSITION : Special Repair Requirement"](#).

>> END

C1116 STOP LAMP SWITCH

< DTC/CIRCUIT DIAGNOSIS >

[VDC/TCS/ABS]

C1116 STOP LAMP SWITCH

Description

INFOID:000000006450512

The stop lamp switch transmits the stop lamp switch signal (ON/OFF) to the ABS actuator and electric unit (control unit).

DTC Logic

INFOID:000000006450513

DTC DETECTION LOGIC

DTC	Display item	Malfunction detected condition	Possible cause
C1116	STOP LAMP SW	When a stop lamp switch signal is not input where the brake pedal is depressed.	<ul style="list-style-type: none">• Harness or connector• Stop lamp switch• ABS actuator and electric unit (control unit)

DTC CONFIRMATION PROCEDURE

1. DTC REPRODUCTION PROCEDURE

1. Turn the ignition switch ON.
2. Perform self-diagnosis for "ABS" with CONSULT-III.

Is DTC "C1116" detected?

- YES >> Proceed to diagnosis procedure. Refer to [BRC-50, "Diagnosis Procedure"](#).
NO >> INSPECTION END

Diagnosis Procedure

INFOID:000000006450514

NOTE:

DTC "C1116" may be detected when the brake pedal and the accelerator pedal are simultaneously depressed for 1 minute or more while driving the vehicle. This is not a malfunction.

1. INTERVIEW FROM THE CUSTOMER

Check if the brake pedal and the accelerator pedal are simultaneously depressed for 1 minute or more while driving the vehicle.

Is there such a history?

- YES >> GO TO 2.
NO >> GO TO 3.

2. PERFORM SELF-DIAGNOSIS

1. Erase self-diagnosis result for "ABS" with CONSULT-III.
2. Turn the ignition switch OFF, and wait 10 seconds or more.
3. Start the engine.

CAUTION:

Never start the vehicle.

4. Depress the brake pedal several times.
5. Perform self-diagnosis for "ABS" with CONSULT-III.

Is DTC "C1116" detected?

- YES >> GO TO 3.
NO >> INSPECTION END

3. STOP LAMP FOR ILLUMINATION

Depress brake pedal and check that stop lamp turns ON.

Does stop lamp turn ON?

- YES >> GO TO 5.
NO >> Check stop lamp system. Refer to [BCS-66, "Wiring Diagram - BCM -"](#). GO TO 4.

4. CHECK DATA MONITOR (1)

1. Erase self-diagnosis result for "ABS" with CONSULT-III.

C1116 STOP LAMP SWITCH

[VDC/TCS/ABS]

< DTC/CIRCUIT DIAGNOSIS >

2. Turn the ignition switch OFF, and wait 10 seconds or more.
3. Start the engine.

CAUTION:

Never start the vehicle.

4. Select "ABS", "DATA MONITOR" and "STOP LAMP SW" according to this order with CONSULT-III. Check that data monitor displays "On" or "Off" when brake pedal is depress or release. Refer to [BRC-90, "Reference Value"](#).
5. Select "ABS", "DATA MONITOR" and "pressure sensor" according to this order. Check that data monitor displays "5 bar" or less when brake pedal is depress. Refer to [BRC-90, "Reference Value"](#).

Is the inspection result normal?

- YES >> INSPECTION END
NO >> GO TO 5.

5.CHECK STOP LAMP SWITCH CLEARANCE

1. Turn the ignition switch OFF.
2. Check stop lamp switch clearance. Refer to [BR-7, "Inspection and Adjustment"](#).

Is the inspection result normal?

- YES >> GO TO 7.
NO >> Adjust stop lamp switch clearance. Refer to [BR-7, "Inspection and Adjustment"](#). GO TO 6.

6.CHECK DATA MONITOR (2)

1. Erase self-diagnosis result for "ABS" with CONSULT-III.
 2. Turn the ignition switch OFF, and wait 10 seconds or more.
 3. Start the engine.
- CAUTION:**
Never start the vehicle.
4. Select "ABS", "DATA MONITOR" and "STOP LAMP SW" according to this order with CONSULT-III. Check that data monitor displays "On" or "Off" when brake pedal is depress or release. Refer to [BRC-90, "Reference Value"](#).
 5. Select "ABS", "DATA MONITOR" and "pressure sensor" according to this order. Check that data monitor displays "5 bar" or less when brake pedal is depress. Refer to [BRC-90, "Reference Value"](#).

Is the inspection result normal?

- YES >> INSPECTION END
NO >> GO TO 7.

7.CHECK STOP LAMP SWITCH

Check stop lamp switch. Refer to [BRC-53, "Component Inspection"](#).

Is the inspection result normal?

- YES >> GO TO 9.
NO >> Replace stop lamp switch. Refer to [BR-18, "Exploded View"](#). GO TO 8.

8.CHECK DATA MONITOR (3)

1. Erase self-diagnosis result for "ABS" with CONSULT-III.
 2. Turn the ignition switch OFF, and wait 10 seconds or more.
 3. Start the engine.
- CAUTION:**
Never start the vehicle.
4. Select "ABS", "DATA MONITOR" and "STOP LAMP SW" according to this order with CONSULT-III. Check that data monitor displays "On" or "Off" when brake pedal is depress or release. Refer to [BRC-90, "Reference Value"](#).
 5. Select "ABS", "DATA MONITOR" and "pressure sensor" according to this order. Check that data monitor displays "5 bar" or less when brake pedal is depress. Refer to [BRC-90, "Reference Value"](#).

Is the inspection result normal?

- YES >> INSPECTION END
NO >> GO TO 9.

9.CHECK CONNECTOR AND TERMINAL

1. Turn the ignition switch OFF.
2. Disconnect ABS actuator and electric unit (control unit) harness connector.

C1116 STOP LAMP SWITCH

[VDC/TCS/ABS]

< DTC/CIRCUIT DIAGNOSIS >

3. Check ABS actuator and electric unit (control unit) harness connector for disconnection or looseness.
4. Check ABS actuator and electric unit (control unit) pin terminals for damage or loose connection with harness connector.
5. Disconnect stop lamp switch harness connector.
6. Check stop lamp switch harness connector for disconnection or looseness.
7. Check stop lamp switch pin terminals for damage or loose connection with harness connector.

Is the inspection result normal?

YES >> GO TO 11.

NO >> Repair or replace error-detected parts. GO TO 10.

10.CHECK DATA MONITOR (4)

1. Connect ABS actuator and electric unit (control unit) harness connector.
2. Connect stop lamp switch harness connector.
3. Erase self-diagnosis result for "ABS" with CONSULT-III.
4. Turn the ignition switch OFF, and wait 10 seconds or more.
5. Start the engine.

CAUTION:

Never start the vehicle.

6. Select "ABS", "DATA MONITOR" and "STOP LAMP SW" according to this order with CONSULT-III. Check that data monitor displays "On" or "Off" when brake pedal is depress or release. Refer to [BRC-90. "Reference Value"](#).
7. Select "ABS", "DATA MONITOR" and "pressure sensor" according to this order. Check that data monitor displays "5 bar" or less when brake pedal is depress. Refer to [BRC-90. "Reference Value"](#).

Is the inspection result normal?

YES >> INSPECTION END

NO >> GO TO 11.

11.CHECK STOP LAMP SWITCH CIRCUIT (1)

1. Turn the ignition switch OFF.
2. Disconnect ABS actuator and electric unit (control unit) harness connector.
3. Check voltage between ABS actuator and electric unit (control unit) harness connector and ground.

ABS actuator and electric unit (control unit)		—	Condition	Voltage
Connector	Terminal			
E41	30	Ground	Brake pedal depressed	Battery voltage
			Brake pedal not depressed	Approx. 0 V

4. Turn the ignition switch ON.
5. Check voltage between ABS actuator and electric unit (control unit) harness connector and ground.

ABS actuator and electric unit (control unit)		—	Condition	Voltage
Connector	Terminal			
E41	30	Ground	Brake pedal depressed	Battery voltage
			Brake pedal not depressed	Approx. 0 V

Is the inspection result normal?

YES >> Replace ABS actuator and electric unit (control unit). Refer to [BRC-118. "Exploded View"](#).

NO >> Repair or replace error-detected parts. GO TO 12.

12.CHECK STOP LAMP SWITCH CIRCUIT (2)

1. Turn the ignition switch OFF.
2. Disconnect stop lamp switch harness connector.
3. Check continuity between ABS actuator and electric unit (control unit) harness connector and stop lamp switch harness connector.

C1116 STOP LAMP SWITCH

< DTC/CIRCUIT DIAGNOSIS >

[VDC/TCS/ABS]

ABS actuator and electric unit (control unit)		Stop lamp switch		Continuity
Connector	Terminal	Connector	Terminal	
E41	30	E110*1	4	Existed
		E119*2	2	

*1: With ICC

*2: Without ICC

4. Check continuity between ABS actuator and electric unit (control unit) harness connector and the ground.

ABS actuator and electric unit (control unit)		—	Continuity
Connector	Terminal		
E41	30	Ground	Not existed

Is the inspection result normal?

YES >> Replace ABS actuator and electric unit (control unit). Refer to [BRC-118, "Exploded View"](#).

NO >> Repair or replace error-detected parts. GO TO 13.

13.CHECK DATA MONITOR (5)

1. Connect ABS actuator and electric unit (control unit) harness connector.
2. Connect stop lamp switch harness connector.
3. Erase self-diagnosis result for "ABS" with CONSULT-III.
4. Turn the ignition switch OFF, and wait 10 seconds or more.
5. Start the engine.
CAUTION:
Never start the vehicle.
6. Select "ABS", "DATA MONITOR" and "STOP LAMP SW" according to this order with CONSULT-III. Check that data monitor displays "On" or "Off" when brake pedal is depress or release. Refer to [BRC-90, "Reference Value"](#).
7. Select "ABS", "DATA MONITOR" and "pressure sensor" according to this order. Check that data monitor displays "5 bar" or less when brake pedal is depress. Refer to [BRC-90, "Reference Value"](#).

Is the inspection result normal?

YES >> INSPECTION END

NO >> Replace ABS actuator and electric unit (control unit). Refer to [BRC-118, "Exploded View"](#).

Component Inspection

INFOID:000000006450515

1.CHECK STOP LAMP SWITCH

1. Turn the ignition switch OFF.
2. Disconnect stop lamp switch connector.
3. Check the continuity between stop lamp switch connector terminals.

Stop lamp switch	Condition	Continuity
Terminal		
1 – 2 (Without ICC) 3 – 4 (With ICC)	Release stop lamp switch (When brake pedal is depressed.)	Existed
	Push stop lamp switch (When brake pedal is released.)	Not existed

Is the inspection result normal?

YES >> INSPECTION END

NO >> Replace stop lamp switch. Refer to [BR-18, "Exploded View"](#).

Special Repair Requirement

INFOID:000000006450516

1.ADJUSTMENT OF STEERING ANGLE SENSOR NEUTRAL POSITION

C1116 STOP LAMP SWITCH

< DTC/CIRCUIT DIAGNOSIS >

[VDC/TCS/ABS]

Always perform the neutral position adjustment for the steering angle sensor, when replacing the ABS actuator and electric unit (control unit). Refer to [BRC-9, "ADJUSTMENT OF STEERING ANGLE SENSOR NEUTRAL POSITION : Special Repair Requirement"](#).

>> END

C1120, C1122, C1124, C1126 IN ABS SOL

< DTC/CIRCUIT DIAGNOSIS >

[VDC/TCS/ABS]

C1120, C1122, C1124, C1126 IN ABS SOL

Description

INFOID:000000006450517

The solenoid valve increases, holds or decreases the fluid pressure of each brake caliper according to the signals transmitted by the ABS actuator and electric unit (control unit).

DTC Logic

INFOID:000000006450518

DTC DETECTION LOGIC

DTC	Display item	Malfunction detected condition	Possible cause
C1120	FR LH IN ABS SOL	When the control unit detects a malfunction in the front LH inlet solenoid circuit.	ABS actuator and electric unit (control unit)
C1122	FR RH IN ABS SOL	When the control unit detects a malfunction in the front RH inlet solenoid circuit.	
C1124	RR LH IN ABS SOL	When the control unit detects a malfunction in the rear LH inlet solenoid circuit.	
C1126	RR RH IN ABS SOL	When the control unit detects a malfunction in the rear RH inlet solenoid circuit.	

DTC CONFIRMATION PROCEDURE

1. DTC REPRODUCTION PROCEDURE

1. Turn the ignition switch ON.
2. Perform self-diagnosis for "ABS" with CONSULT-III.

Is DTC "C1120", "C1122", "C1124" or "C1126" detected?

- YES >> Proceed to diagnosis procedure. Refer to [BRC-55, "Diagnosis Procedure"](#).
NO >> INSPECTION END

Diagnosis Procedure

INFOID:000000006450519

1. CHECK CONNECTOR

1. Turn the ignition switch OFF.
2. Disconnect ABS actuator and electric unit (control unit) connector.
3. Check terminal for deformation, disconnection, looseness, etc.

Is the inspection result normal?

- YES >> GO TO 2.
NO >> Repair or replace error-detected parts.

2. CHECK SOLENOID, VDC SWITCH-OVER VALVE AND ACTUATOR RELAY POWER SUPPLY CIRCUIT

1. Check the 30A fusible link (L).
2. Check the voltage between ABS actuator and electric unit (control unit) harness connector and ground.

ABS actuator and electric unit (control unit)		—	Voltage
Connector	Terminal		
E41	3	Ground	Battery voltage

Is the inspection result normal?

- YES >> GO TO 3.
NO >> Perform the trouble diagnosis for battery power supply circuit. Refer to [PG-6, "Wiring Diagram - BATTERY POWER SUPPLY -"](#).

3. CHECK SOLENOID, VDC SWITCH-OVER VALVE AND ACTUATOR RELAY GROUND CIRCUIT

Check the continuity between ABS actuator and electric unit (control unit) harness connector and ground.

C1120, C1122, C1124, C1126 IN ABS SOL

< DTC/CIRCUIT DIAGNOSIS >

[VDC/TCS/ABS]

ABS actuator and electric unit (control unit)		—	Continuity
Connector	Terminal		
E41	1	Ground	Existed
	4		

Is the inspection result normal?

YES >> Replace ABS actuator and electric unit (control unit).

NO >> Repair or replace error-detected parts.

Special Repair Requirement

INFOID:000000006450520

1. ADJUSTMENT OF STEERING ANGLE SENSOR NEUTRAL POSITION

Always perform the neutral position adjustment for the steering angle sensor, when replacing the ABS actuator and electric unit (control unit). Refer to [BRC-9. "ADJUSTMENT OF STEERING ANGLE SENSOR NEUTRAL POSITION : Special Repair Requirement"](#).

>> END

C1121, C1123, C1125, C1127 OUT ABS SOL

< DTC/CIRCUIT DIAGNOSIS >

[VDC/TCS/ABS]

C1121, C1123, C1125, C1127 OUT ABS SOL

Description

INFOID:000000006450521

The solenoid valve increases, holds or decreases the fluid pressure of each brake caliper according to the signals transmitted by the ABS actuator and electric unit (control unit).

DTC Logic

INFOID:000000006450522

DTC DETECTION LOGIC

DTC	Display item	Malfunction detected condition	Possible cause
C1121	FR LH OUT ABS SOL	When the control unit detects a malfunction in the front LH outlet solenoid circuit.	ABS actuator and electric unit (control unit)
C1123	FR RH OUT ABS SOL	When the control unit detects a malfunction in the front RH outlet solenoid circuit.	
C1125	RR LH OUT ABS SOL	When the control unit detects a malfunction in the rear LH outlet solenoid circuit.	
C1127	RR RH OUT ABS SOL	When the control unit detects a malfunction in the rear RH outlet solenoid circuit.	

DTC CONFIRMATION PROCEDURE

1. DTC REPRODUCTION PROCEDURE

1. Turn the ignition switch ON.
2. Perform self-diagnosis for "ABS" with CONSULT-III.

Is DTC "C1121", "C1123", "C1125" or "C1127" detected?

- YES >> Proceed to diagnosis procedure. Refer to [BRC-57, "Diagnosis Procedure"](#).
 NO >> INSPECTION END

Diagnosis Procedure

INFOID:000000006450523

1. CHECK CONNECTOR

1. Turn the ignition switch OFF.
2. Disconnect ABS actuator and electric unit (control unit) connector.
3. Check terminal for deformation, disconnection, looseness, etc.

Is the inspection result normal?

- YES >> GO TO 2.
 NO >> Repair or replace error-detected parts.

2. CHECK SOLENOID, VDC SWITCH-OVER VALVE AND ACTUATOR RELAY POWER SUPPLY CIRCUIT

1. Check the 30A fusible link (L).
2. Check the voltage between ABS actuator and electric unit (control unit) harness connector and ground.

ABS actuator and electric unit (control unit)		—	Voltage
Connector	Terminal		
E41	3	Ground	Battery voltage

Is the inspection result normal?

- YES >> GO TO 3.
 NO >> Perform the trouble diagnosis for battery power supply circuit. Refer to [PG-6, "Wiring Diagram - BATTERY POWER SUPPLY -"](#).

3. CHECK SOLENOID, VDC SWITCH-OVER VALVE AND ACTUATOR RELAY GROUND CIRCUIT

Check the continuity between ABS actuator and electric unit (control unit) harness connector and ground.

C1121, C1123, C1125, C1127 OUT ABS SOL

< DTC/CIRCUIT DIAGNOSIS >

[VDC/TCS/ABS]

ABS actuator and electric unit (control unit)		—	Continuity
Connector	Terminal		
E41	1	Ground	Existed
	4		

Is the inspection result normal?

YES >> Replace ABS actuator and electric unit (control unit).

NO >> Repair or replace error-detected parts.

Special Repair Requirement

INFOID:000000006450524

1. ADJUSTMENT OF STEERING ANGLE SENSOR NEUTRAL POSITION

Always perform the neutral position adjustment for the steering angle sensor, when replacing the ABS actuator and electric unit (control unit). Refer to [BRC-9. "ADJUSTMENT OF STEERING ANGLE SENSOR NEUTRAL POSITION : Special Repair Requirement"](#).

>> END

C1130, C1131, C1132 ENGINE SIGNAL

< DTC/CIRCUIT DIAGNOSIS >

[VDC/TCS/ABS]

C1130, C1131, C1132 ENGINE SIGNAL

Description

INFOID:000000006450525

ABS actuator and electric unit (control unit) and ECM exchange the engine signal with CAN communication line.

DTC Logic

INFOID:000000006450526

DTC DETECTION LOGIC

DTC	Display item	Malfunction detected condition	Possible cause
C1130	ENGINE SIGNAL 1	Major engine components are malfunctioning.	<ul style="list-style-type: none">• Harness or connector• ABS actuator and electric unit (control unit)• ECM• CAN communication line
C1131	ENGINE SIGNAL 2		
C1132	ENGINE SIGNAL 3		

DTC CONFIRMATION PROCEDURE

1. DTC REPRODUCTION PROCEDURE

1. Turn the ignition switch ON.
2. Perform self-diagnosis for "ABS" with CONSULT-III.

Is DTC "C1130", "C1131" or "C1132" detected?

- YES >> Proceed to diagnosis procedure. Refer to [BRC-59, "Diagnosis Procedure"](#).
NO >> INSPECTION END

Diagnosis Procedure

INFOID:000000006450527

1. ECM SELF-DIAGNOSIS

Perform self-diagnosis for "ENGINE" with CONSULT-III.

Is any item indicated on the self-diagnosis display?

- YES >> Check the malfunctioning system.
NO >> GO TO 2.

2. ABS ACTUATOR AND ELECTRIC UNIT (CONTROL UNIT) SELF-DIAGNOSIS

1. Erase self-diagnosis results for "ABS" with CONSULT-III.
2. Turn the ignition switch OFF.
3. Start the engine. Drive the vehicle for a while.
4. Make sure that malfunction indicator lamp (MIL) turns OFF.
5. Stop the engine. Perform self-diagnosis for "ABS" with CONSULT-III.

Is DTC "C1130", "C1131" or "C1132" detected?

- YES >> Replace ABS actuator and electric unit (control unit).
NO >> Check ABS actuator and electric unit (control unit) pin terminals for damage or loose connection with harness connector. If any items are damaged, repair or replace error-detected parts.

Special Repair Requirement

INFOID:000000006450528

1. ADJUSTMENT OF STEERING ANGLE SENSOR NEUTRAL POSITION

Always perform the neutral position adjustment for the steering angle sensor, when replacing the ABS actuator and electric unit (control unit). Refer to [BRC-9, "ADJUSTMENT OF STEERING ANGLE SENSOR NEUTRAL POSITION : Special Repair Requirement"](#).

>> END

C1138 4WAS SYSTEM

Description

INFOID:000000006450529

The ABS actuator and electric unit (control unit) and the 4WAS control unit exchange signals via the CAN communication line.

DTC Logic

INFOID:000000006450530

DTC DETECTION LOGIC

DTC	Display item	Malfunction detected condition	Possible cause
C1138	4WAS CIRCUIT	Abnormal condition in major 4WAS parts.	<ul style="list-style-type: none"> • ABS actuator and electric unit (control unit) • 4WAS system • CAN communication line

DTC CONFIRMATION PROCEDURE

1. CHECK SELF-DIAGNOSIS RESULTS

1. Turn the ignition switch ON.
2. Perform self-diagnosis for "ABS" with CONSULT-III.

Is DTC "C1138" detected?

- YES >> Proceed to diagnosis procedure. Refer to [BRC-60. "Diagnosis Procedure"](#).
 NO >> INSPECTION END

Diagnosis Procedure

INFOID:000000006450531

1.

Perform self-diagnosis for "4WAS(FRONT)" and "4WAS(MAIN/RAS/HICAS)" with CONSULT-III.

Is any item indicated on the self-diagnosis display?

- YES >> Check the malfunction system.
 NO >> GO TO 2.

2. ABS ACTUATOR AND ELECTRIC UNIT (CONTROL UNIT) SELF-DIAGNOSIS

1. Erase self-diagnosis results for "ABS" with CONSULT-III.
2. Turn the ignition switch OFF.
3. Start the engine. Drive the vehicle for a while.
4. Make sure that 4WAS warning lamp turns OFF.
5. Stop the engine. Perform self-diagnosis for "ABS" with CONSULT-III.

Is DTC "C1138" detected?

- YES >> Replace ABS actuator and electric unit (control unit).
 NO >> Check ABS actuator and electric unit (control unit) pin terminals for damage or loose connection with harness connector. If any items and damaged, repair or replace error-detected parts.

Special Repair Requirement

INFOID:000000006450532

1. ADJUSTMENT OF STEERING ANGLE SENSOR NEUTRAL POSITION

Always perform the neutral position adjustment for the steering angle sensor, when replacing the ABS actuator and electric unit (control unit). Refer to [BRC-9. "ADJUSTMENT OF STEERING ANGLE SENSOR NEUTRAL POSITION : Special Repair Requirement"](#).

>> END

C1140 ACTUATOR RELAY SYSTEM

< DTC/CIRCUIT DIAGNOSIS >

[VDC/TCS/ABS]

C1140 ACTUATOR RELAY SYSTEM

Description

INFOID:000000006450504

Activates or deactivates each solenoid valve according to the signals transmitted by the ABS actuator and electric unit (control unit).

DTC Logic

INFOID:000000006450505

DTC DETECTION LOGIC

DTC	Display item	Malfunction detected condition	Possible cause
C1140	ACTUATOR RLY	During the actuator relay operating with OFF, when the actuator relay turns ON, or when the control line for the relay is shorted to the ground.	<ul style="list-style-type: none">• Harness or connector• ABS actuator and electric unit (control unit)
		During the actuator relay operating with ON, when the actuator relay turns ON, or when the control line for the relay is open.	

DTC CONFIRMATION PROCEDURE

1. DTC REPRODUCTION PROCEDURE

1. Turn the ignition switch ON.
2. Perform self-diagnosis for "ABS" with CONSULT-III.

Is DTC "C1140" detected?

- YES >> Proceed to diagnosis procedure. Refer to [BRC-61, "Diagnosis Procedure"](#).
NO >> INSPECTION END

Diagnosis Procedure

INFOID:000000006450506

1. CHECK CONNECTOR

1. Turn the ignition switch OFF.
2. Disconnect ABS actuator and electric unit (control unit) connector.
3. Check terminal for deformation, disconnection, looseness, etc.

Is the inspection result normal?

- YES >> GO TO 2.
NO >> Repair or replace error-detected parts.

2. CHECK SOLENOID, VDC SWITCH-OVER VALVE AND ACTUATOR RELAY POWER SUPPLY CIRCUIT

1. Check the 30A fusible link (L).
2. Check the voltage between ABS actuator and electric unit (control unit) harness connector and ground.

ABS actuator and electric unit (control unit)		—	Voltage
Connector	Terminal		
E41	3	Ground	Battery voltage

Is the inspection result normal?

- YES >> GO TO 3.
NO >> Perform the trouble diagnosis for battery power supply circuit. Refer to [PG-6, "Wiring Diagram - BATTERY POWER SUPPLY -"](#).

3. CHECK SOLENOID, VDC SWITCH-OVER VALVE AND ACTUATOR RELAY GROUND CIRCUIT

Check the continuity between ABS actuator and electric unit (control unit) harness connector and ground.

C1140 ACTUATOR RELAY SYSTEM

< DTC/CIRCUIT DIAGNOSIS >

[VDC/TCS/ABS]

ABS actuator and electric unit (control unit)		—	Continuity
Connector	Terminal		
E41	1	Ground	Existed
	4		

Is the inspection result normal?

YES >> Replace ABS actuator and electric unit (control unit).

NO >> Repair or replace error-detected parts.

Special Repair Requirement

INFOID:000000006450507

1. ADJUSTMENT OF STEERING ANGLE SENSOR NEUTRAL POSITION

Always perform the neutral position adjustment for the steering angle sensor, when replacing the ABS actuator and electric unit (control unit). Refer to [BRC-9. "ADJUSTMENT OF STEERING ANGLE SENSOR NEUTRAL POSITION : Special Repair Requirement"](#).

>> END

C1142 PRESS SENSOR

< DTC/CIRCUIT DIAGNOSIS >

[VDC/TCS/ABS]

C1142 PRESS SENSOR

Description

INFOID:000000006450533

The pressure sensor converts the brake fluid pressure to an electric signal and transmits it to the ABS actuator and electric unit (control unit). [The pressure sensor is integrated in the ABS actuator and electric unit (control unit).]

DTC Logic

INFOID:000000006450534

DTC DETECTION LOGIC

DTC	Display item	Malfunction detected condition	Possible cause
C1142	PRESS SEN CIRCUIT	Pressure sensor signal line is open or shorted, or pressure sensor is malfunctioning.	<ul style="list-style-type: none">• Harness or connector• Stop lamp switch• ABS actuator and electric unit (control unit)

DTC CONFIRMATION PROCEDURE

1. DTC REPRODUCTION PROCEDURE

1. Turn the ignition switch ON.
2. Perform self-diagnosis for "ABS" with CONSULT-III.

Is DTC "C1142" detected?

- YES >> Proceed to diagnosis procedure. Refer to [BRC-63, "Diagnosis Procedure"](#).
NO >> INSPECTION END

Diagnosis Procedure

INFOID:000000006450535

1. CHECK STOP LAMP SWITCH

Check stop lamp switch system. Refer to [BRC-50, "Diagnosis Procedure"](#).

Is the inspection result normal?

- YES >> GO TO 2.
NO >> Repair or replace malfunction component.

2. CHECK BRAKE SYSTEM

1. Check brake fluid leakage: Refer to [BR-10, "Inspection"](#).
2. Check front brake piping: Refer to [BR-24, "FRONT : Inspection"](#).
3. Check rear brake piping: Refer to [BR-27, "REAR : Inspection"](#).
4. Check brake pedal: Refer to [BR-19, "Inspection and Adjustment"](#).
5. Check master cylinder: Refer to [BR-31, "Inspection"](#).
6. Check brake booster: Refer to [BR-33, "Inspection and Adjustment"](#).
7. Check brake booster pressure sensor: Refer to [BR-35, "Inspection"](#).
8. Check vacuum lines: Refer to [BR-36, "Inspection"](#).
9. Check front disc brake: Refer to [BR-45, "BRAKE CALIPER ASSEMBLY \(1 PISTON TYPE\) : Inspection"](#) (1 piston type), [BR-49, "BRAKE CALIPER ASSEMBLY \(4 PISTON TYPE\) : Inspection"](#) (4 piston type).
10. Check rear disc brake: Refer to [BR-58, "BRAKE CALIPER ASSEMBLY \(1 PISTON TYPE\) : Inspection"](#) (1 piston type), [BR-62, "BRAKE CALIPER ASSEMBLY \(2 PISTON TYPE\) : Inspection"](#) (2 piston type).

Is the inspection result normal?

- YES >> GO TO 3.
NO >> Repair or replace error-detected parts.

3. ABS ACTUATOR AND ELECTRIC UNIT (CONTROL UNIT) SELF-DIAGNOSIS

Perform self-diagnosis for "ABS" with CONSULT-III.

Is DTC "C1142" detected?

- YES >> Replace ABS actuator and electric unit (control unit).
NO >> Check ABS actuator and electric unit (control unit) pin terminals for damage or loose connection with harness connector. If any items are damaged, repair or replace error-detected parts.

C1142 PRESS SENSOR

< DTC/CIRCUIT DIAGNOSIS >

[VDC/TCS/ABS]

Special Repair Requirement

INFOID:000000006450536

1. ADJUSTMENT OF STEERING ANGLE SENSOR NEUTRAL POSITION

Always perform the neutral position adjustment for the steering angle sensor, when replacing the ABS actuator and electric unit (control unit). Refer to [BRC-9. "ADJUSTMENT OF STEERING ANGLE SENSOR NEUTRAL POSITION : Special Repair Requirement"](#).

>> END

C1143 STEERING ANGLE SENSOR

< DTC/CIRCUIT DIAGNOSIS >

[VDC/TCS/ABS]

C1143 STEERING ANGLE SENSOR

Description

INFOID:000000006450537

The steering angle sensor detects the rotation amount, angular velocity and direction of the steering wheel, and transmits the data to the ABS actuator and electric unit (control unit) via CAN communication.

DTC Logic

INFOID:000000006450538

DTC DETECTION LOGIC

DTC	Display item	Malfunction detected condition	Possible cause
C1143	ST ANG SEN CIRCUIT	Steering angle sensor is malfunctioning.	<ul style="list-style-type: none"> • Harness or connector • Steering angle sensor • ABS actuator and electric unit (control unit)

DTC CONFIRMATION PROCEDURE

1. DTC REPRODUCTION PROCEDURE

1. Turn the ignition switch ON.
2. Perform self-diagnosis for "ABS" with CONSULT-III.

Is DTC "C1143" detected?

- YES >> Proceed to diagnosis procedure. Refer to [BRC-65. "Diagnosis Procedure"](#).
 NO >> INSPECTION END

Diagnosis Procedure

INFOID:000000006450539

1. CHECK CONNECTOR

1. Turn the ignition switch OFF.
2. Disconnect ABS actuator and electric unit (control unit) connector.
3. Disconnect steering angle sensor connector.
4. Check terminal for deformation, disconnection, looseness, etc.

Is the inspection result normal?

- YES >> GO TO 2.
 NO >> Repair or replace error-detected parts.

2. CHECK STEERING ANGLE SENSOR POWER SUPPLY

1. Check the voltage between steering angle sensor harness connector and ground.

Steering angle sensor		—	Condition	Voltage
Connector	Terminal			
M37	8	Ground	Ignition switch: OFF	Approx. 0 V

2. Turn the ignition switch ON.
CAUTION:
Never start the engine.
3. Check the voltage between steering angle sensor harness connector and ground.

Steering angle sensor		—	Condition	Voltage
Connector	Terminal			
M37	8	Ground	Ignition switch: ON	Battery voltage

Is the inspection result normal?

- YES >> GO TO 4.
 NO >> GO TO 3.

3. CHECK STEERING ANGLE SENSOR POWER SUPPLY CIRCUIT

C1143 STEERING ANGLE SENSOR

[VDC/TCS/ABS]

< DTC/CIRCUIT DIAGNOSIS >

1. Turn the ignition switch OFF.
2. Check 10 A fusible link (45).
3. Disconnect IPDM E/R harness connector.
4. Check continuity between steering angle sensor harness connector and IPDM E/R harness connector.

Steering angle sensor		IPDM E/R		Continuity
Connector	Terminal	Connector	Terminal	
M37	8	E5	25	Existed

Is the inspection result normal?

YES >> Perform the trouble diagnosis for ignition power supply circuit. Refer to [PG-67, "Wiring Diagram - IGNITION POWER SUPPLY -"](#).

NO >> Repair or replace error-detected parts.

4.CHECK STEERING ANGLE SENSOR GROUND

Check continuity between steering angle sensor harness connector and ground.

Steering angle sensor		—	Continuity
Connector	Terminal		
M37	7	Ground	Existed

Is the inspection result normal?

YES >> GO TO 5.

NO >> Repair or replace error-detected parts.

5.CHECK DATA LINE

Check "STRG BRANCH LINE CIRCUIT". Refer to [LAN-56, "Diagnosis Procedure"](#).

Is the inspection result normal?

YES >> Replace ABS actuator and electric unit (control unit).

NO >> Repair or replace error-detected parts.

Special Repair Requirement

INFOID:000000006450540

1.AJUSTMENT OF STEERING ANGLE SENSOR NEUTRAL POSITION

Always perform the neutral position adjustment for the steering angle sensor, when replacing the steering angle sensor or the ABS actuator and electric unit (control unit). Refer to [BRC-9, "ADJUSTMENT OF STEERING ANGLE SENSOR NEUTRAL POSITION : Description"](#).

>> END

C1144 INCOMPLETE STEERING ANGLE SENSOR ADJUSTMENT

< DTC/CIRCUIT DIAGNOSIS >

[VDC/TCS/ABS]

C1144 INCOMPLETE STEERING ANGLE SENSOR ADJUSTMENT

DTC Logic

INFOID:000000006450541

DTC DETECTION LOGIC

DTC	Display item	Malfunction detected condition	Possible cause
C1144	ST ANG SEN SIGNAL	Neutral position of steering angle sensor is not finished.	<ul style="list-style-type: none">• Harness or connector• Steering angle sensor• ABS actuator and electric unit (control unit)

DTC CONFIRMATION PROCEDURE

1. DTC REPRODUCTION PROCEDURE

1. Turn the ignition switch ON.
2. Select "ABS", "WORK SUPPORT" and "ST ANGLE SENSOR ADJUSTMENT" in order with CONSULT-III, and perform adjust the neutral position of steering angle sensor.
3. Perform self-diagnosis for "ABS" with CONSULT-III.

Is DTC "C1144" detected?

- YES >> Proceed to diagnosis procedure. Refer to [BRC-67. "Diagnosis Procedure"](#).
NO >> INSPECTION END

Diagnosis Procedure

INFOID:000000006450542

1. CHECK STEERING ANGLE SENSOR

Check steering angle sensor. Refer to [BRC-65. "Diagnosis Procedure"](#).

Is the inspection result normal?

- YES >> Replace ABS actuator and electric unit (control unit).
NO >> Repair or replace error-detected parts.

Special Repair Requirement

INFOID:000000006450543

1. ADJUSTMENT OF STEERING ANGLE SENSOR NEUTRAL POSITION

Always perform the neutral position adjustment for the steering angle sensor, when replacing the steering angle sensor or the ABS actuator and electric unit (control unit). Refer to [BRC-9. "ADJUSTMENT OF STEERING ANGLE SENSOR NEUTRAL POSITION : Description"](#).

>> END

A
B
C
D
E
BRC
G
H
I
J
K
L
M
N
O
P

C1145, C1146 YAW RATE/SIDE G SENSOR

< DTC/CIRCUIT DIAGNOSIS >

[VDC/TCS/ABS]

C1145, C1146 YAW RATE/SIDE G SENSOR

Description

INFOID:000000006450544

The yaw rate/side G sensor detects the yaw rate/side G affecting the vehicle, and transmits the data to the ABS actuator and electric unit (control unit) as an analog voltage signal.

DTC Logic

INFOID:000000006450545

DTC DETECTION LOGIC

DTC	Display item	Malfunction detected condition	Possible cause
C1145	YAW RATE SENSOR	Yaw rate sensor is malfunctioning, or the yaw rate sensor signal line is open or shorted.	• Harness or connector • ABS actuator and electric unit (control unit) • Yaw rate/side G sensor
C1146	SIDE G-SEN CIRCUIT	Side G sensor is malfunctioning, or circuit of side G sensor is open or shorted.	

DTC CONFIRMATION PROCEDURE

1. DTC REPRODUCTION PROCEDURE

1. Turn the ignition switch ON.
2. Perform self-diagnosis for "ABS" with CONSULT-III.

Is DTC "C1145" or "C1146" detected?

- YES >> Proceed to diagnosis procedure. Refer to [BRC-68, "Diagnosis Procedure"](#).
NO >> INSPECTION END

Diagnosis Procedure

INFOID:000000006450546

CAUTION:

- Sudden turns (such as spin turns, acceleration turns), drifting, etc., when VDC function is off (VDC OFF switch "ON") may cause yaw rate/side G sensor system to indicate a malfunction. However, this is not a malfunction, if normal operation can be resumed after restarting engine. Then erase memory of self-diagnosis.
- If vehicle is on turn-table at entrance to parking garage, or on other moving surface, VDC warning lamp may illuminate and CONSULT-III self-diagnosis may indicate yaw rate sensor system malfunction. However, in this case there is no malfunction in yaw rate sensor system. Take vehicle off of turn-table or other moving surface, and start the engine. Results will return to normal.

1. CHECK CONNECTOR

1. Turn the ignition switch OFF.
2. Disconnect ABS actuator and electric unit (control unit) connector.
3. Disconnect yaw rate/side G sensor connector.
4. Check terminal for deformation, disconnection, looseness, etc.

Is the inspection result normal?

- YES >> GO TO 2.
NO >> Repair or replace error-detected parts.

2. CHECK YAW RATE/SIDE G SENSOR POWER SUPPLY

1. Check the voltage between yaw rate/side G sensor harness connector and ground.

Yaw rate/side G sensor		—	Condition	Voltage
Connector	Terminal			
M143	4	Ground	Ignition switch: OFF	Approx. 0 V

2. Turn the ignition switch ON.

CAUTION:

Never start the engine.

3. Check the voltage between yaw rate/side G sensor harness connector and ground.

C1145, C1146 YAW RATE/SIDE G SENSOR

< DTC/CIRCUIT DIAGNOSIS >

[VDC/TCS/ABS]

Yaw rate/side G sensor		—	Condition	Voltage
Connector	Terminal			
M143	4	Ground	Ignition switch: ON	Battery voltage

Is the inspection result normal?

- YES >> GO TO 4.
- NO >> GO TO 3.

3. CHECK YAW RATE/SIDE G SENSOR POWER SUPPLY CIRCUIT

1. Turn the ignition switch OFF.
2. Check 10 A fusible link (#45).
3. Disconnect IPDM E/R harness connector.
4. Check the continuity between ABS actuator and electric unit (control unit) harness connector and IPDM E/R harness connector.

Yaw rate/side G sensor		IPDM E/R		Continuity
Connector	Terminal	Connector	Terminal	
M143	4	E5	25	Existed

Is the inspection result normal?

- YES >> Perform the trouble diagnosis for ignition power supply circuit. Refer to [PG-6. "Wiring Diagram - BATTERY POWER SUPPLY -"](#).
- NO >> Repair or replace error-detected parts.

4. CHECK YAW RATE/SIDE G SENSOR GROUND

Check the continuity between yaw rate/side G sensor harness connector and ground.

Yaw rate/side G sensor		—	Continuity
Connector	Terminal		
M143	1	Ground	Existed

Is the inspection result normal?

- YES >> GO TO 5.
- NO >> Repair or replace error-detected parts.

5. CHECK YAW RATE/SIDE G SENSOR HARNESS

Check the continuity between yaw rate/side G sensor harness connector and ABS actuator and electric unit (control unit) harness connector.

ABS actuator and electric unit (control unit)		Yaw rate/side G sensor		Continuity
Connector	Terminal	Connector	Terminal	
E41	25	M143	2	Existed
	45		3	

Is the inspection result normal?

- YES >> GO TO 6.
- NO >> Repair or replace error-detected parts. Refer to [BRC-113. "Precautions for Harness Repair"](#).

6. REPLACE YAW RATE/SIDE G SENSOR

1. Replace yaw rate/side G sensor.
2. Erase self-diagnosis results for "ABS" with CONSULT-III.
3. Turn the ignition switch OFF.
4. Turn the ignition switch ON.

CAUTION:

Never start the engine.

5. Perform self-diagnosis for "ABS" with CONSULT-III.

Is DTC "C1145" or "C1146" detected?

C1145, C1146 YAW RATE/SIDE G SENSOR

< DTC/CIRCUIT DIAGNOSIS >

[VDC/TCS/ABS]

YES >> Replace ABS actuator and electric unit (control unit).
NO >> INSPECTION END

Special Repair Requirement

INFOID:000000006450547

1. ADJUSTMENT OF STEERING ANGLE SENSOR NEUTRAL POSITION

Always perform the neutral position adjustment for the steering angle sensor, when replacing the ABS actuator and electric unit (control unit). Refer to [BRC-9, "ADJUSTMENT OF STEERING ANGLE SENSOR NEUTRAL POSITION : Special Repair Requirement"](#).

>> END

C1147, C1148, C1149, C1150 USV/HSV LINE

< DTC/CIRCUIT DIAGNOSIS >

[VDC/TCS/ABS]

C1147, C1148, C1149, C1150 USV/HSV LINE

Description

INFOID:000000006450548

USV1, USV2 (CUT VALVE)

The cut valve shuts off the normal brake fluid path from the master cylinder, when VDC/TCS is activated.

HSV1, HSV2 (SUCTION VALVE)

The suction valve supplies the brake fluid from the master cylinder to the pump, when VDC/TCS is activated.

DTC Logic

INFOID:000000006450549

DTC DETECTION LOGIC

DTC	Display item	Malfunction detected condition	Possible cause
C1147	USV LINE[FL-RR]	VDC switch-over solenoid valve (USV1) on the primary side is open circuit or shorted, or the control line is open or shorted to the power supply or the ground.	<ul style="list-style-type: none"> • Harness or connector • ABS actuator and electric unit (control unit)
C1148	USV LINE[FR-RL]	VDC switch-over solenoid valve (USV2) on the primary side is open circuit or shorted, or the control line is open or shorted to the power supply or the ground.	
C1149	HSV LINE[FL-RR]	VDC switch-over solenoid valve (HSV1) on the primary side is open circuit or shorted, or the control line is open or shorted to the power supply or the ground.	
C1150	HSV LINE[FR-RL]	VDC switch-over solenoid valve (HSV2) on the primary side is open circuit or shorted, or the control line is open or shorted to the power supply or the ground.	

DTC CONFIRMATION PROCEDURE

1. DTC REPRODUCTION PROCEDURE

1. Turn the ignition switch ON.
2. Perform self-diagnosis for "ABS" with CONSULT-III.

Is DTC "C1147", "C1148", "C1149" or "C1150" detected?

- YES >> Proceed to diagnosis procedure. Refer to [BRC-71, "Diagnosis Procedure"](#).
 NO >> INSPECTION END

Diagnosis Procedure

INFOID:000000006450550

1. CHECK CONNECTOR

1. Turn the ignition switch OFF.
2. Disconnect ABS actuator and electric unit (control unit) connector.
3. Check terminal for deformation, disconnection, looseness, etc.

Is the inspection result normal?

- YES >> GO TO 2.
 NO >> Repair or replace error-detected parts.

2. CHECK SOLENOID, VDC SWITCH-OVER VALVE AND ACTUATOR RELAY POWER SUPPLY CIRCUIT

1. Check the 30A fusible link (L).
2. Check the voltage between ABS actuator and electric unit (control unit) harness connector and ground.

ABS actuator and electric unit (control unit)		—	Voltage
Connector	Terminal		
E41	3	Ground	Battery voltage

Is the inspection result normal?

- YES >> GO TO 3.

C1147, C1148, C1149, C1150 USV/HSV LINE

< DTC/CIRCUIT DIAGNOSIS >

[VDC/TCS/ABS]

NO >> Perform the trouble diagnosis for battery power supply circuit. Refer to [PG-6. "Wiring Diagram - BATTERY POWER SUPPLY -"](#).

3.CHECK SOLENOID, VDC SWITCH-OVER VALVE AND ACTUATOR RELAY GROUND CIRCUIT

Check the continuity between ABS actuator and electric unit (control unit) harness connector and ground.

ABS actuator and electric unit (control unit)		—	Continuity
Connector	Terminal		
E41	1	Ground	Existed
	4		

Is the inspection result normal?

YES >> Replace ABS actuator and electric unit (control unit).

NO >> Repair or replace error-detected parts.

Special Repair Requirement

INFOID:000000006450551

1.AJUSTMENT OF STEERING ANGLE SENSOR NEUTRAL POSITION

Always perform the neutral position adjustment for the steering angle sensor, when replacing the ABS actuator and electric unit (control unit). Refer to [BRC-9. "ADJUSTMENT OF STEERING ANGLE SENSOR NEUTRAL POSITION : Special Repair Requirement"](#).

>> END

C1155 BRAKE FLUID LEVEL SWITCH

< DTC/CIRCUIT DIAGNOSIS >

[VDC/TCS/ABS]

C1155 BRAKE FLUID LEVEL SWITCH

Description

INFOID:000000006450552

The brake fluid level switch converts the brake fluid level to an electric signal and transmits it to the ABS actuator and electric unit (control unit).

DTC Logic

INFOID:000000006450553

DTC DETECTION LOGIC

DTC	Display item	Malfunction detected condition	Possible cause
C1155	BR FLUID LEVEL LOW	Brake fluid level is low or communication line between the ABS actuator and electric unit (control unit) and brake fluid level switch is open or shorted.	<ul style="list-style-type: none">• Harness or connector• Brake fluid level switch• Unified meter and A/C amp.

DTC CONFIRMATION PROCEDURE

1. DTC REPRODUCTION PROCEDURE

1. Turn the ignition switch ON.
2. Perform self-diagnosis for "ABS" with CONSULT-III.

Is DTC "C1155" detected?

- YES >> Proceed to diagnosis procedure. Refer to [BRC-73. "Diagnosis Procedure"](#).
NO >> INSPECTION END

Diagnosis Procedure

INFOID:000000006450554

1. CHECK BRAKE FLUID LEVEL

1. Turn the ignition switch OFF.
2. Check brake fluid level. Refer to [BR-10. "Inspection"](#).

Is the inspection result normal?

- YES >> GO TO 2.
NO >> Refill brake fluid. Refer to [BR-10. "Refilling"](#).

2. PERFORM SELF-DIAGNOSIS (1)

1. Erase self-diagnosis result for "ABS" with CONSULT-III.
2. Turn the ignition switch OFF, and wait 10 seconds or more.
3. Turn the ignition switch ON.

CAUTION:

Never start the engine.

4. Perform self-diagnosis for "ABS" with CONSULT-III.

Is DTC "C1155" detected?

- YES >> INSPECTION END
NO >> GO TO 3.

3. CHECK BRAKE FLUID LEVEL SWITCH

Check brake fluids level switch. Refer to [BRC-75. "Component Inspection"](#).

Is the inspection result normal?

- YES >> GO TO 5.
NO >> Replace reservoir tank. Refer to [BR-29. "Exploded View"](#). GO TO 4.

4. PERFORM SELF-DIAGNOSIS (2)

1. Erase self-diagnosis result for "ABS" with CONSULT-III.
2. Turn the ignition switch OFF, and wait 10 seconds or more.
3. Turn the ignition switch ON.

CAUTION:

Never start the engine.

4. Perform self-diagnosis for "ABS" with CONSULT-III.

C1155 BRAKE FLUID LEVEL SWITCH

[VDC/TCS/ABS]

< DTC/CIRCUIT DIAGNOSIS >

Is DTC "C1155" detected?

- YES >> INSPECTION END
- NO >> GO TO 5.

5. CHECK CONNECTOR AND TERMINAL

1. Turn the ignition switch OFF.
2. Disconnect brake fluid level switch harness connector.
3. Check brake fluid level switch harness connector for disconnection or looseness.
4. Check brake fluid level switch pin terminals for damage or loose connection with harness connector.
5. Disconnect combination meter harness connector.
6. Check combination meter harness connector for disconnection or looseness.
7. Check combination meter pin terminals for damage or loose connection with harness connector.

Is the inspection result normal?

- YES >> GO TO 7.
- NO >> Repair or replace error-detected parts. GO TO 6.

6. PERFORM SELF-DIAGNOSIS (3)

1. Connect brake fluid level switch harness connector.
2. Connect combination meter harness connector.
3. Erase self-diagnosis result for "ABS" with CONSULT-III.
4. Turn the ignition switch OFF, and wait 10 seconds or more.
5. Turn the ignition switch ON.

CAUTION:

Never start the engine.

6. Perform self-diagnosis for "ABS" with CONSULT-III.

Is DTC "C1155" detected?

- YES >> INSPECTION END
- NO >> GO TO 7.

7. CHECK BRAKE FLUID LEVEL SWITCH HARNESS

1. Turn the ignition switch OFF.
2. Disconnect brake fluid level switch harness connector.
3. Disconnect combination meter harness connector.
4. Check continuity between brake fluid level switch harness connector and combination meter harness connector.

Brake fluid level switch		Combination meter		Continuity
Connector	Terminal	Connector	Terminal	
E47	1	M53	28	Existed

5. Check continuity between brake fluid level switch harness connector and ground.

Brake fluid level switch		—	Continuity
Connector	Terminal		
E47	1	Ground	Not existed

Is the inspection result normal?

- YES >> GO TO 8.
- NO >> Repair or replace error-detected parts. GO TO 8.

8. CHECK BRAKE FLUID LEVEL SWITCH GROUND

Check continuity between brake fluid level switch harness connector and ground.

Brake fluid level switch		—	Continuity
Connector	Terminal		
E47	2	Ground	Existed

Is the inspection result normal?

C1155 BRAKE FLUID LEVEL SWITCH

[VDC/TCS/ABS]

< DTC/CIRCUIT DIAGNOSIS >

- YES >> GO TO 9.
NO >> Repair or replace error-detected parts. GO TO 9.

9.CHECK COMBINATION METER

Check combination meter. Refer to [MWI-38. "CONSULT-III Function \(METER/M&A\)".](#)

Is the inspection result normal?

- YES >> Replace ABS actuator and electric unit (control unit). Refer to [BRC-118. "Exploded View".](#)
NO >> Repair or replace combination meter. Refer to [MWI-129. "Exploded View".](#)

Component Inspection

INFOID:000000006450555

1.CHECK BRAKE FLUID LEVEL SWITCH

1. Turn the ignition switch OFF.
2. Disconnect brake fluid level switch connector.
3. Check the continuity between brake fluid level switch connector terminals.

Brake fluid level switch	Condition	Continuity
Terminal		
1 - 2	When brake fluid is full in the reservoir tank.	Not existed
	When brake fluid is empty in the reservoir tank.	Existed

Is the inspection result normal?

- YES >> INSPECTION END
NO >> Replace reservoir tank. Refer to [BR-29. "Exploded View".](#)

Special Repair Requirement

INFOID:000000006450556

1.ADJUSTMENT OF STEERING ANGLE SENSOR NEUTRAL POSITION

Always perform the neutral position adjustment for the steering angle sensor, when replacing the ABS actuator and electric unit (control unit). Refer to [BRC-9. "ADJUSTMENT OF STEERING ANGLE SENSOR NEUTRAL POSITION : Special Repair Requirement".](#)

>> END

A
B
C
D
E
G
H
I
J
K
L
M
N
O
P

BRC

C1185 ICC UNIT

< DTC/CIRCUIT DIAGNOSIS >

[VDC/TCS/ABS]

C1185 ICC UNIT

Description

INFOID:000000006450557

The ABS actuator and electric unit (control unit) and the ICC sensor integrated unit exchange signals via the CAN communication line.

DTC Logic

INFOID:000000006450558

DTC DETECTION LOGIC

DTC	Display item	Malfunction detected condition	Possible cause
C1185	ACC CONT	ICC sensor integrated unit internal malfunction.	<ul style="list-style-type: none">• Harness or connector• ICC sensor integrated unit• ABS actuator and electric unit (control unit)• CAN communication line

DTC CONFIRMATION PROCEDURE

1. DTC REPRODUCTION PROCEDURE

1. Turn the ignition switch ON.
2. Perform self-diagnosis for "ABS" with CONSULT-III.

Is DTC "C1185" detected?

- YES >> Proceed to diagnosis procedure. Refer to [BRC-76. "Diagnosis Procedure"](#).
NO >> INSPECTION END

Diagnosis Procedure

INFOID:000000006450559

1. CHECK ICC SENSOR INTEGRATED UNIT CIRCUIT

Perform self-diagnosis for "ICC" with CONSULT-III.

Is any item indicated on the self-diagnosis display?

- YES >> Repair or replace error-detected parts.
NO >> GO TO 2.

2. CHECK ABS ACTUATOR AND ELECTRIC UNIT (CONTROL UNIT)

Perform self-diagnosis for "ABS" with CONSULT-III.

Is DTC "C1185" detected?

- YES >> Repair or replace error-detected parts.
NO >> INSPECTION END

Special Repair Requirement

INFOID:000000006450560

1. ADJUSTMENT OF STEERING ANGLE SENSOR NEUTRAL POSITION

Always perform the neutral position adjustment for the steering angle sensor, when replacing the ABS actuator and electric unit (control unit). Refer to [BRC-9. "ADJUSTMENT OF STEERING ANGLE SENSOR NEUTRAL POSITION : Special Repair Requirement"](#).

>> END

U1000 CAN COMM CIRCUIT

< DTC/CIRCUIT DIAGNOSIS >

[VDC/TCS/ABS]

U1000 CAN COMM CIRCUIT

Description

INFOID:000000006450561

CAN (Controller Area Network) is a serial communication line for real time application. It is an on-vehicle multiplex communication line with high data communication speed and excellent error detection ability. Many electronic control units are equipped onto a vehicle, and each control unit shares information and links with other control units during operation (not independent). In CAN communication, control units are connected with 2 communication lines (CAN-H line, CAN-L line) allowing a high rate of information transmission with less wiring. Each control unit transmits/receives data but selectively reads required data only.

DTC Logic

INFOID:000000006450562

DTC DETECTION LOGIC

DTC	Display item	Malfunction detected condition	Possible cause
U1000	CAN COMM CIRCUIT	When ABS actuator and electric unit (control unit) is not transmitting or receiving CAN communication signal for 2 seconds or more.	<ul style="list-style-type: none">CAN communication lineABS actuator and electric unit (control unit)

BRC

DTC CONFIRMATION PROCEDURE

1. DTC REPRODUCTION PROCEDURE

- Turn the ignition switch ON.
- Perform self-diagnosis for "ABS" with CONSULT-III.

Is DTC "U1000" detected?

- YES >> Proceed to diagnosis procedure. Refer to [BRC-77. "Diagnosis Procedure"](#).
NO >> INSPECTION END

Diagnosis Procedure

INFOID:000000006450563

1. PERFORM ABS ACTUATOR AND ELECTRIC UNIT (CONTROL UNIT)

Perform self-diagnosis for "ABS" with CONSULT-III.

Is DTC "U1000" detected?

- YES >> Proceed to diagnosis procedure. Refer to [LAN-16. "Trouble Diagnosis Flow Chart"](#).
NO >> INSPECTION END

Special Repair Requirement

INFOID:000000006450564

1. ADJUSTMENT OF STEERING ANGLE SENSOR NEUTRAL POSITION

Always perform the neutral position adjustment for the steering angle sensor, when replacing the ABS actuator and electric unit (control unit). Refer to [BRC-9. "ADJUSTMENT OF STEERING ANGLE SENSOR NEUTRAL POSITION : Special Repair Requirement"](#).

>> END

U1002 SYSTEM COMM (CAN)

Description

INFOID:000000006450565

CAN (Controller Area Network) is a serial communication line for real time application. It is an on-vehicle multiplex communication line with high data communication speed and excellent error detection ability. Many electronic control units are equipped onto a vehicle, and each control unit shares information and links with other control units during operation (not independent). In CAN communication, control units are connected with 2 communication lines (CAN-H line, CAN-L line) allowing a high rate of information transmission with less wiring. Each control unit transmits/receives data but selectively reads required data only.

DTC Logic

INFOID:000000006450566

DTC DETECTION LOGIC

DTC	Display item	Malfunction detected condition	Possible cause
U1002	SYSTEM COMM (CAN)	When ABS actuator and electric unit (control unit) is not transmitting or receiving CAN communication signal for 2 seconds or less.	<ul style="list-style-type: none"> CAN communication line ABS actuator and electric unit (control unit)

DTC CONFIRMATION PROCEDURE

1. DTC REPRODUCTION PROCEDURE

1. Turn the ignition switch ON.
2. Perform self-diagnosis for "ABS" with CONSULT-III.

Is DTC "U1002" detected?

- YES >> Proceed to diagnosis procedure. Refer to [BRC-78. "Diagnosis Procedure"](#).
 NO >> INSPECTION END

Diagnosis Procedure

INFOID:000000006450567

CAUTION:

- Never apply 7.0 V or more to the measurement terminal.
- Use a tester with open terminal voltage of 7.0 V or less.
- Turn the ignition switch OFF and disconnect the battery cable from the negative terminal when checking the harness.

1. CHECK CAN DIAGNOSIS SUPPORT MONITOR

1. Select "ABS" and "CAN Diagnosis Support Monitor" in order with CONSULT-III.
2. Check malfunction history between each control unit connected to ABS actuator and electric unit (control unit).

Check the result of "PAST"?

- All items are "OK">>Check intermittent incident. Refer to [GI-43. "Intermittent Incident"](#).
 "TRANSMIT DIAG" is other than "OK">>GO TO 2.
 A control unit other than ABS actuator and electric unit (control unit) is anything other than "OK">>GO TO 3.

2. CHECK TRANSMITTING SIDE UNIT

Check the ABS actuator and electric unit (control unit) harness connector terminals No. 25 and 45 for damage or loose connection.

Is the inspection result normal?

- YES >> Erase self-diagnosis results. Then perform self-diagnosis for "ABS" with CONSULT-III.
 NO >> Recheck terminals for damage or loose connection. Refer to [LAN-6. "Precautions for Harness Repair"](#).

3. CHECK APPLICABLE CONTROL UNIT

Check terminals of each harness connector for damage or loose connection.

Is the inspection result normal?

- YES >> Erase self-diagnosis results. Then perform self-diagnosis for applicable control unit with CONSULT-III.

U1002 SYSTEM COMM (CAN)

< DTC/CIRCUIT DIAGNOSIS >

[VDC/TCS/ABS]

NO >> Recheck terminals for damage or loose connection. Refer to [LAN-6. "Precautions for Harness Repair"](#).

Special Repair Requirement

INFOID:000000006450568

1. ADJUSTMENT OF STEERING ANGLE SENSOR NEUTRAL POSITION

Always perform the neutral position adjustment for the steering angle sensor, when replacing the ABS actuator and electric unit (control unit). Refer to [BRC-9. "ADJUSTMENT OF STEERING ANGLE SENSOR NEUTRAL POSITION : Special Repair Requirement"](#).

>> END

A
B
C
D
E
G
H
I
J
K
L
M
N
O
P

BRC

POWER SUPPLY AND GROUND CIRCUIT

< DTC/CIRCUIT DIAGNOSIS >

[VDC/TCS/ABS]

POWER SUPPLY AND GROUND CIRCUIT

Description

INFOID:000000006450569

Supplies power to ABS actuator and electric unit (control unit).

Diagnosis Procedure

INFOID:000000006450570

1. CHECK ABS ACTUATOR AND ELECTRIC UNIT (CONTROL UNIT) IGNITION POWER SUPPLY

1. Turn the ignition switch OFF.
2. Disconnect ABS actuator and electric unit (control unit) harness connector.
3. Check the voltage between ABS actuator and electric unit (control unit) harness connector and ground.

ABS actuator and electric unit (control unit)		—	Condition	Voltage
Connector	Terminal			
E41	28	Ground	Ignition switch: OFF	Approx. 0 V

4. Turn the ignition switch ON.
CAUTION:
Never start the engine.
5. Check the voltage between ABS actuator and electric unit (control unit) harness connector and ground.

ABS actuator and electric unit (control unit)		—	Condition	Voltage
Connector	Terminal			
E41	28	Ground	Ignition switch: ON	Battery voltage

Is the inspection result normal?

- YES >> GO TO 3.
NO >> GO TO 2.

2. CHECK ABS ACTUATOR AND ELECTRIC UNIT (CONTROL UNIT) IGNITION POWER SUPPLY CIRCUIT

1. Turn the ignition switch OFF.
2. Check 10A fusible link (45).
3. Disconnect IPDM E/R harness connector.
4. Check continuity between ABS actuator and electric unit (control unit) harness connector and IPDM E/R harness connector.

ABS actuator and electric unit (control unit)		IPDM E/R		Continuity
Connector	Terminal	Connector	Terminal	
E41	28	E5	25	Existed

Is the inspection result normal?

- YES >> Perform the trouble diagnosis for ignition power supply circuit. Refer to [PG-67. "Wiring Diagram - IGNITION POWER SUPPLY -"](#).
NO >> Repair or replace error-detected parts.

3. CHECK ABS ACTUATOR AND ELECTRIC UNIT (CONTROL UNIT) BATTERY POWER SUPPLY

1. Turn the ignition switch OFF.
2. Check the voltage between ABS actuator and electric unit (control unit) harness connector and ground.

ABS actuator and electric unit (control unit)		—	Voltage
Connector	Terminal		
E41	2	Ground	Battery voltage
	3		

Is the inspection result normal?

POWER SUPPLY AND GROUND CIRCUIT

[VDC/TCS/ABS]

< DTC/CIRCUIT DIAGNOSIS >

YES >> GO TO 4.

NO >> Perform the trouble diagnosis for battery power supply circuit. Refer to [PG-6, "Wiring Diagram - BATTERY POWER SUPPLY -"](#).

4.CHECK ABS ACTUATOR AND ELECTRIC UNIT (CONTROL UNIT) GROUND

Check the continuity between ABS actuator and electric unit (control unit) harness connector and ground.

ABS actuator and electric unit (control unit)		—	Continuity
Connector	Terminal		
E41	1	Ground	Existed
	4		

Is the inspection result normal?

YES >> INSPECTION END

NO >> Repair or replace error-detected parts.

A
B
C
D
E
G
H
I
J
K
L
M
N
O
P

BRC

PARKING BRAKE SWITCH

< DTC/CIRCUIT DIAGNOSIS >

[VDC/TCS/ABS]

PARKING BRAKE SWITCH

Description

INFOID:000000006450571

The parking brake switch converts the status of the parking brake lever (M/T models) or the parking brake pedal (A/T models) to an electric signal and transmits it to the ABS actuator and electric unit (control unit).

Component Function Check

INFOID:000000006450572

1. CHECK PARKING BRAKE SWITCH OPERATION

Operate the parking brake lever (M/T models) or the parking brake pedal (A/T models). Then check that the brake warning lamp in the combination meter turns on/off correctly.

Condition	Brake warning lamp illumination status
When the parking brake switch is operation	ON
When the parking brake switch is not operation.	OFF

Is the inspection result normal?

YES >> INSPECTION END

NO >> Go to diagnosis procedure. Refer to [BRC-82, "Diagnosis Procedure"](#).

Diagnosis Procedure

INFOID:000000006450573

1. CHECK PARKING BRAKE SWITCH

Check parking brake switch. Refer to [BRC-82, "Component Inspection"](#).

Is the inspection result normal?

YES >> GO TO 2.

NO >> Replace parking brake switch.

2. CHECK COMBINATION METER

Check if the indication and operation of combination meter are normal. Refer to [MWI-36, "Diagnosis Description"](#).

Is the inspection result normal?

YES >> GO TO 3.

NO >> Repair or replace combination meter.

3. CHECK DATA MONITOR

Select "ABS", "DATA MONITOR" and "PARK BRAKE SW" in order with CONSULT-III, and perform the parking brake switch inspection.

Condition	PARK BRAKE SW (DATA MONITOR)
Parking brake switch is active	On
Parking brake switch is inactive	Off

Is the inspection result normal?

YES >> INSPECTION END

NO >> Check unified meter and A/C amp. Refer to [MWI-38, "CONSULT-III Function \(METER/M&A\)"](#).

Component Inspection

INFOID:000000006450574

1. CHECK PARKING BRAKE SWITCH

1. Turn ignition switch OFF.
2. Disconnect parking brake switch connector.
3. Check continuity between parking brake switch connector terminal.

PARKING BRAKE SWITCH

< DTC/CIRCUIT DIAGNOSIS >

[VDC/TCS/ABS]

Parking brake switch Terminal	—	Condition	Continuity
1	Ground	When the parking brake switch is operated.	Existed
		When the parking brake switch is not operated.	Not existed

Is the inspection result normal?

- YES >> INSPECTION END
- NO >> Replace parking brake switch.

A
B
C
D
E
G
H
I
J
K
L
M
N
O
P

BRC

VDC OFF SWITCH

< DTC/CIRCUIT DIAGNOSIS >

[VDC/TCS/ABS]

VDC OFF SWITCH

Description

INFOID:000000006450575

VDC OFF switch can deactivate (turn OFF) the VDC/TCS function by pressing the VDC OFF switch.

Component Function Check

INFOID:000000006450576

1.CHECK VDC OFF SWITCH OPERATION

Turn ON/OFF the VDC OFF switch and check that the VDC OFF indicator lamp in the combination meter turns ON/OFF correctly.

Condition	VDC OFF indicator lamp illumination status
Press the VDC OFF switch when VDC OFF indicator OFF.	ON
Press the VDC OFF switch when VDC OFF indicator ON.	OFF

Is the inspection result normal?

YES >> INSPECTION END

NO >> Proceed to diagnosis procedure. Refer to [BRC-84, "Diagnosis Procedure"](#).

Diagnosis Procedure

INFOID:000000006450577

1.CHECK VDC OFF SWITCH

Check VDC OFF switch. Refer to [BRC-85, "Component Inspection"](#).

Is the inspection result normal?

YES >> GO TO 2.

NO >> VDC OFF switch is malfunctioning. Replace VDC OFF switch.

2.CHECK VDC OFF SWITCH HARNESS

1. Disconnect ABS actuator and electric unit (control unit) connector.
2. Disconnect VDC OFF switch connector.
3. Check continuity between VDC OFF switch connector and ABS actuator and electric unit (control unit) connector.

ABS actuator and electric unit (control unit)		VDC OFF switch		Continuity
Connector	Terminal	Connector	Terminal	
E41	31	M19	1	Existed

4. Check continuity between ABS actuator and electric unit (control unit) connector and ground.

ABS actuator and electric unit (control unit)		—	Continuity
Connector	Terminal		
E41	31	Ground	Not existed

5. Check continuity between VDC OFF switch connector and ground.

VDC OFF switch		—	Continuity
Connector	Terminal		
M19	2	Ground	Existed

Is the inspection result normal?

YES >> GO TO 3.

NO >> Repair or replace error-detected parts.

3.CHECK COMBINATION METER

1. Connect ABS actuator and electric unit (control unit) connector.

VDC OFF SWITCH

[VDC/TCS/ABS]

< DTC/CIRCUIT DIAGNOSIS >

2. Connect VDC OFF switch connector.
3. Check if the indication and operation of combination meter are normal. Refer to [MWI-36, "Diagnosis Description"](#).

Is the inspection result normal?

- YES >> Replace ABS actuator and electric unit (control unit).
NO >> Repair or replace combination meter.

Component Inspection

INFOID:000000006450578

1. CHECK VDC OFF SWITCH

1. Turn ignition switch OFF.
2. Disconnect VDC OFF switch connector.
3. Check continuity between VDC OFF switch connector terminals.

VDC OFF switch	Condition	Continuity
Terminal		
1 - 2	When VDC OFF switch is hold pressed.	Existed
	When releasing VDC OFF switch.	Not existed

Is the inspection result normal?

- YES >> INSPECTION END
NO >> Replace VDC OFF switch.

A
B
C
D
E
G
H
I
J
K
L
M
N
O
P

BRC

ABS WARNING LAMP

< DTC/CIRCUIT DIAGNOSIS >

[VDC/TCS/ABS]

ABS WARNING LAMP

Description

INFOID:000000006450579

×: ON –: OFF

Condition	ABS warning lamp
Ignition switch OFF	–
For 1 second after turning ignition switch ON	×
1 second later after turning ignition switch ON	–
ABS function is malfunctioning.	×
EBD function is malfunctioning.	×

Component Function Check

INFOID:000000006450580

1.CHECK ABS WARNING LAMP OPERATION

Check that the lamp illuminates for approximately 1 second after the ignition switch is turned ON.

Is the inspection result normal?

YES >> INSPECTION END

NO >> Proceed to diagnosis procedure. Refer to [BRC-86. "Diagnosis Procedure"](#).

Diagnosis Procedure

INFOID:000000006450581

1.CHECK SELF-DIAGNOSIS

Perform self-diagnosis for "ABS" with CONSULT-III.

Is the inspection result normal?

YES >> GO TO 2.

NO >> Check items displayed by self-diagnosis.

2.CHECK COMBINATION METER

Check if the indication and operation of combination meter are normal. Refer to [MWI-36. "Diagnosis Description"](#).

Is the inspection result normal?

YES >> Replace ABS actuator and electric unit (control unit).

NO >> Repair or replace combination meter.

BRAKE WARNING LAMP

< DTC/CIRCUIT DIAGNOSIS >

[VDC/TCS/ABS]

BRAKE WARNING LAMP

Description

INFOID:000000006450582

×: ON –: OFF

Condition	Brake warning lamp (Note 1)
Ignition switch OFF	–
For 1 second after turning ignition switch ON	× (Note 2)
1 second later after turning ignition switch ON	× (Note 2)
EBD function is malfunctioning.	×

NOTE:

- 1: Brake warning lamp will turn on in case of parking brake operation (when switch is ON) or of brake fluid level switch operation (when brake fluid is insufficient).
- 2: After starting engine, brake warning lamp is turned off.

Component Function Check

INFOID:000000006450583

BRC

1. BRAKE WARNING LAMP OPERATION CHECK 1

Check that the lamp illuminates for approximately 1 second after the ignition switch is turned ON.

Is the inspection result normal?

YES >> GO TO 2.

NO >> Proceed to diagnosis procedure. Refer to [BRC-87, "Diagnosis Procedure"](#).

2. BRAKE WARNING LAMP OPERATION CHECK 2

Check that the brake warning lamp in the combination meter turns ON/OFF correctly when operating the parking brake lever (M/T models) or the parking brake pedal (A/T models).

Is the inspection result normal?

YES >> INSPECTION END

NO >> Check parking brake switch. Refer to [BRC-82, "Diagnosis Procedure"](#).

Diagnosis Procedure

INFOID:000000006450584

1. CHECK PARKING BRAKE SWITCH

Check that the brake warning lamp in the combination meter turns ON/OFF correctly when operating the parking brake lever (M/T models) or the parking brake pedal (A/T models).

Is the inspection result normal?

YES >> GO TO 2.

NO >> Check parking brake switch. Refer to [BRC-82, "Diagnosis Procedure"](#).

2. CHECK SELF-DIAGNOSIS

Perform self-diagnosis for "ABS" with CONSULT-III.

Is the inspection result normal?

YES >> GO TO 3.

NO >> Check items displayed by self-diagnosis.

3. CHECK COMBINATION METER

Check if the indication and operation of combination meter are normal. Refer to [MWI-36, "Diagnosis Description"](#).

Is the inspection result normal?

YES >> Replace ABS actuator and electric unit (control unit).

NO >> Repair or replace combination meter.

VDC OFF INDICATOR LAMP

< DTC/CIRCUIT DIAGNOSIS >

[VDC/TCS/ABS]

VDC OFF INDICATOR LAMP

Description

INFOID:000000006450585

×: ON –: OFF

Condition	VDC OFF indicator lamp
Ignition switch OFF	–
For 1 second after turning ignition switch ON	×
1 second later after turning ignition switch ON	–
VDC OFF switch turned ON. (VDC function is OFF.)	×
VDC/TCS function is malfunctioning.	×
ABS function is malfunctioning.	×
EBD function is malfunctioning.	×

Component Function Check

INFOID:000000006450586

1.VDC OFF INDICATOR LAMP OPERATION CHECK 1

Check that the lamp illuminates for approximately 1 second after the ignition switch is turned ON.

Is the inspection result normal?

YES >> GO TO 2.

NO >> Proceed to diagnosis procedure. Refer to [BRC-88, "Diagnosis Procedure"](#).

2.VDC OFF INDICATOR LAMP OPERATION CHECK 2

Check that the VDC OFF indicator lamp in the combination meter turns ON/OFF correctly when operating the VDC OFF switch.

Is the inspection result normal?

YES >> INSPECTION END

NO >> Check VDC OFF switch. Refer to [BRC-84, "Diagnosis Procedure"](#).

Diagnosis Procedure

INFOID:000000006450587

1.CHECK VDC OFF SWITCH

Check that the VDC OFF indicator lamp in the combination meter turns ON/OFF correctly when operating the VDC OFF switch.

Is the inspection result normal?

YES >> GO TO 2.

NO >> Check VDC OFF switch. Refer to [BRC-84, "Diagnosis Procedure"](#).

2.CHECK SELF-DIAGNOSIS

Perform self-diagnosis for "ABS" with CONSULT-III.

Is the inspection result normal?

YES >> GO TO 3.

NO >> Check items displayed by self-diagnosis.

3.CHECK COMBINATION METER

Check if the indication and operation of combination meter are normal. Refer to [MWI-36, "Diagnosis Description"](#).

Is the inspection result normal?

YES >> Replace ABS actuator and electric unit (control unit).

NO >> Repair or replace combination meter.

VDC WARNING LAMP

< DTC/CIRCUIT DIAGNOSIS >

[VDC/TCS/ABS]

VDC WARNING LAMP

Description

INFOID:000000006450588

×: ON –: OFF

Condition	VDC warning lamp
Ignition switch OFF	–
For 1 second after turning ignition switch ON	×
1 second later after turning ignition switch ON	–
VDC/TCS function is malfunctioning.	×
ABS function is malfunctioning.	×
EBD function is malfunctioning.	×

Component Function Check

INFOID:000000006450589

1.CHECK VDC WARNING LAMP OPERATION

Check that the lamp illuminates for approximately 1 second after the ignition switch is turned ON.

Is the inspection result normal?

YES >> INSPECTION END

NO >> Proceed to diagnosis procedure. Refer to [BRC-89. "Diagnosis Procedure"](#).

Diagnosis Procedure

INFOID:000000006450590

1.CHECK SELF-DIAGNOSIS

Perform self-diagnosis for "ABS" with CONSULT-III.

Is the inspection result normal?

YES >> GO TO 2.

NO >> Check items displayed by self-diagnosis.

2.CHECK COMBINATION METER

Check if the indication and operation of combination meter are normal. Refer to [MWI-36. "Diagnosis Description"](#).

Is the inspection result normal?

YES >> Replace ABS actuator and electric unit (control unit).

NO >> Repair or replace combination meter.

ABS ACTUATOR AND ELECTRIC UNIT (CONTROL UNIT)

< ECU DIAGNOSIS INFORMATION >

[VDC/TCS/ABS]

ECU DIAGNOSIS INFORMATION

ABS ACTUATOR AND ELECTRIC UNIT (CONTROL UNIT)

Reference Value

INFOID:000000006450591

VALUES ON THE DIAGNOSIS TOOL

CAUTION:

The display shows the control unit calculation data, so a normal value might be displayed even in the event the output circuit (harness) is open or short-circuited.

CONSULT-III MONITOR ITEM

Monitor item	Display content	Data monitor	
		Condition	Reference value in normal operation
FR LH SENSOR	Wheel speed	Vehicle stopped	0 [km/h (MPH)]
		Vehicle running (Note 1)	Nearly matches the speed meter display (± 10% or less)
FR RH SENSOR	Wheel speed	Vehicle stopped	0 [km/h (MPH)]
		Vehicle running (Note 1)	Nearly matches the speed meter display (± 10% or less)
RR LH SENSOR	Wheel speed	Vehicle stopped	0 [km/h (MPH)]
		Vehicle running (Note 1)	Nearly matches the speed meter display (± 10% or less)
RR RH SENSOR	Wheel speed	Vehicle stopped	0 [km/h (MPH)]
		Vehicle running (Note 1)	Nearly matches the speed meter display (± 10% or less)
STOP LAMP SW	Stop lamp switch signal status	When brake pedal is depressed	On
		When brake pedal is not depressed	Off
BATTERY VOLT	Battery voltage supplied to the ABS actuator and electric unit (control unit)	Ignition switch ON	10 – 16 V
GEAR	Gear position determined by TCM	First gear (1GR) Second gear (2GR) Third gear (3GR) Forth gear (4GR) Fifth gear (5GR)	1 2 3 4 5
SLCT LVR POSI	A/T selector lever position	P position R position N position D position	P R N D
OFF SW	VDC OFF switch ON/OFF	VDC OFF switch ON (When VDC OFF indicator lamp is ON)	On
		VDC OFF switch OFF (When VDC OFF indicator lamp is OFF)	Off
YAW RATE SEN	Yaw rate detected by yaw rate/side G sensor	Vehicle stopped	Approx. 0 d/s
		Turning right	Negative value
		Turning left	Positive value
ACCEL POS SIG	Throttle actuator opening/closing is displayed (linked with accelerator pedal)	Accelerator pedal not depressed (ignition switch is ON)	0 %
		Depress accelerator pedal (ignition switch is ON)	0 - 100 %

ABS ACTUATOR AND ELECTRIC UNIT (CONTROL UNIT)

< ECU DIAGNOSIS INFORMATION >

[VDC/TCS/ABS]

Monitor item	Display content	Data monitor		
		Condition	Reference value in normal operation	
SIDE G-SENSOR	Transverse G detected by side G sensor	Vehicle stopped	Approx. 0 m/s ²	A
		Turning right	Negative value (m/s ²)	B
		Turning left	Positive value (m/s ²)	C
STR ANGLE SIG	Steering angle detected by steering angle sensor	Straight-ahead	±2.5°	
		Turn 90° to right	Approx. +90°	D
		Turn 90° to left	Approx. -90°	
4WD MODE MON (Note 2)	AWD activated	Engine running	AUTO	E
PRESS SENSOR	Brake fluid pressure detected by pressure sensor	With ignition switch turned ON and brake pedal released	Approx. 0 bar	
		With ignition switch turned ON and brake pedal depressed	-40 to 300 bar	BRC
ENGINE RPM	With engine running	With engine stopped	0 [tr/min (rpm)]	G
		Engine running	Almost in accordance with tachometer display	H
FLUID LEV SW	Brake fluid level switch signal status	When brake fluid level switch ON	On	
		When brake fluid level switch OFF	Off	
PARK BRAKE SW	Parking brake switch signal status	Parking brake switch is active	On	I
		Parking brake switch is inactive	Off	
FR RH IN SOL	Operation status of each solenoid valve	Actuator (solenoid valve) is active ("ACTIVE TEST" in "ABS" with CONSULT-III)	On	J
		When the actuator (solenoid valve) is not active and actuator relay is active (ignition switch ON)	Off	K
FR RH OUT SOL	Operation status of each solenoid valve	Actuator (solenoid valve) is active ("ACTIVE TEST" in "ABS" with CONSULT-III)	On	
		When the actuator (solenoid valve) is not active and actuator relay is active (ignition switch ON)	Off	L
FR LH IN SOL	Operation status of each solenoid valve	Actuator (solenoid valve) is active ("ACTIVE TEST" in "ABS" with CONSULT-III)	On	M
		When the actuator (solenoid valve) is not active and actuator relay is active (ignition switch ON)	Off	N
FR LH OUT SOL	Operation status of each solenoid valve	Actuator (solenoid valve) is active ("ACTIVE TEST" in "ABS" with CONSULT-III)	On	
		When the actuator (solenoid valve) is not active and actuator relay is active (ignition switch ON)	Off	O
RR RH IN SOL	Operation status of each solenoid valve	Actuator (solenoid valve) is active ("ACTIVE TEST" in "ABS" with CONSULT-III)	On	P
		When the actuator (solenoid valve) is not active and actuator relay is active (ignition switch ON)	Off	

ABS ACTUATOR AND ELECTRIC UNIT (CONTROL UNIT)

< ECU DIAGNOSIS INFORMATION >

[VDC/TCS/ABS]

Monitor item	Display content	Data monitor	
		Condition	Reference value in normal operation
RR RH OUT SOL	Operation status of each solenoid valve	Actuator (solenoid valve) is active ("ACTIVE TEST" in "ABS" with CONSULT-III)	On
		When the actuator (solenoid valve) is not active and actuator relay is active (ignition switch ON)	Off
RR LH IN SOL	Operation status of each solenoid valve	Actuator (solenoid valve) is active ("ACTIVE TEST" in "ABS" with CONSULT-III)	On
		When the actuator (solenoid valve) is not active and actuator relay is active (ignition switch ON)	Off
RR LH OUT SOL	Operation status of each solenoid valve	Actuator (solenoid valve) is active ("ACTIVE TEST" in "ABS" with CONSULT-III)	On
		When the actuator (solenoid valve) is not active and actuator relay is active (ignition switch ON)	Off
MOTOR RELAY	Motor and motor relay operation	When the motor relay and motor are operating	On
		When the motor relay and motor are not operating	Off
ACTUATOR RLY (Note 3)	Actuator relay operation	When the actuator relay is operating	On
		When the actuator relay is not operating	Off
ABS WARN LAMP	ABS warning lamp (Note 4)	When ABS warning lamp is ON	On
		When ABS warning lamp is OFF	Off
OFF LAMP	VDC OFF indicator lamp (Note 4)	When VDC OFF indicator lamp is ON	On
		When VDC OFF indicator lamp is OFF	Off
SLIP/VDC LAMP	VDC warning lamp (Note 4)	When VDC warning lamp is ON	On
		When VDC warning lamp is OFF	Off
BST OPER SIG	Not applied but displayed	—	Off
EBD SIGNAL	EBD operation	EBD is active	On
		EBD is inactive	Off
ABS SIGNAL	ABS operation	ABS is active	On
		ABS is inactive	Off
TCS SIGNAL	TCS operation	TCS is active	On
		TCS is inactive	Off
VDC SIGNAL	VDC operation	VDC is active	On
		VDC is inactive	Off
EBD FAIL SIG	EBD fail-safe signal	In EBD fail-safe	On
		EBD is normal	Off
ABS FAIL SIG	ABS fail-safe signal	In ABS fail-safe	On
		ABS is normal	Off
TCS FAIL SIG	TCS fail-safe signal	In TCS fail-safe	On
		TCS is normal	Off
VDC FAIL SIG	VDC fail-safe signal	In VDC fail-safe	On
		VDC is normal	Off
CRANKING SIG	Crank operation	Crank is active	On
		Crank is inactive	Off

ABS ACTUATOR AND ELECTRIC UNIT (CONTROL UNIT)

< ECU DIAGNOSIS INFORMATION >

[VDC/TCS/ABS]

Monitor item	Display content	Data monitor	
		Condition	Reference value in normal operation
USV [FL-RR] (Note 3)	VDC switch-over valve	When actuator (switch-over valve) is active ("ACTIVE TEST" in "ABS" with CONSULT-III)	On
		When actuator (switch-over valve) is not active and actuator relay is active (ignition switch ON)	Off
USV [FR-RL] (Note 3)	VDC switch-over valve	When actuator (switch-over valve) is active ("ACTIVE TEST" in "ABS" with CONSULT-III)	On
		When actuator (switch-over valve) is not active and actuator relay is active (ignition switch ON)	Off
HSV [FL-RR] (Note 3)	VDC switch-over valve	When actuator (switch-over valve) is active ("ACTIVE TEST" in "ABS" with CONSULT-III)	On
		When actuator (switch-over valve) is not active and actuator relay is active (ignition switch ON)	Off
HSV [FR-RL] (Note 3)	VDC switch-over valve	When actuator (switch-over valve) is active ("ACTIVE TEST" in "ABS" with CONSULT-III)	On
		When actuator (switch-over valve) is not active and actuator relay is active (ignition switch ON)	Off
V/R OUTPUT (Note 3)	Solenoid valve relay activated	When the solenoid valve relay is active (When ignition switch OFF)	On
		When the solenoid valve relay is not active (in the fail-safe mode)	Off
M/R OUTPUT	Actuator motor and motor relay activated	When the actuator motor and motor relay are active ("ACTIVE TEST" in "ABS" with CONSULT-III)	On
		When the actuator motor and motor relay are inactive	Off

NOTE:

- 1: Confirm tire pressure is normal.
- 2: Only AWD models.
- 3: A brief moment of On/Off condition occurs every 20 seconds after ignition switch turned ON. This is not malfunction because it is an operation for checking.
- 4: On and off timing for warning lamp and indicator lamp.
 - ABS warning lamp: Refer to [BRC-86, "Description"](#).
 - Brake warning lamp: Refer to [BRC-87, "Description"](#).
 - VDC OFF indicator lamp: Refer to [BRC-88, "Description"](#).
 - VDC warning lamp: Refer to [BRC-89, "Description"](#).

A
B
C
D
E
BRC
G
H
I
J
K
L
M
N
O
P

ABS ACTUATOR AND ELECTRIC UNIT (CONTROL UNIT)

< ECU DIAGNOSIS INFORMATION >

[VDC/TCS/ABS]

Wiring Diagram - BRAKE CONTROL SYSTEM -

INFOID:000000006450592

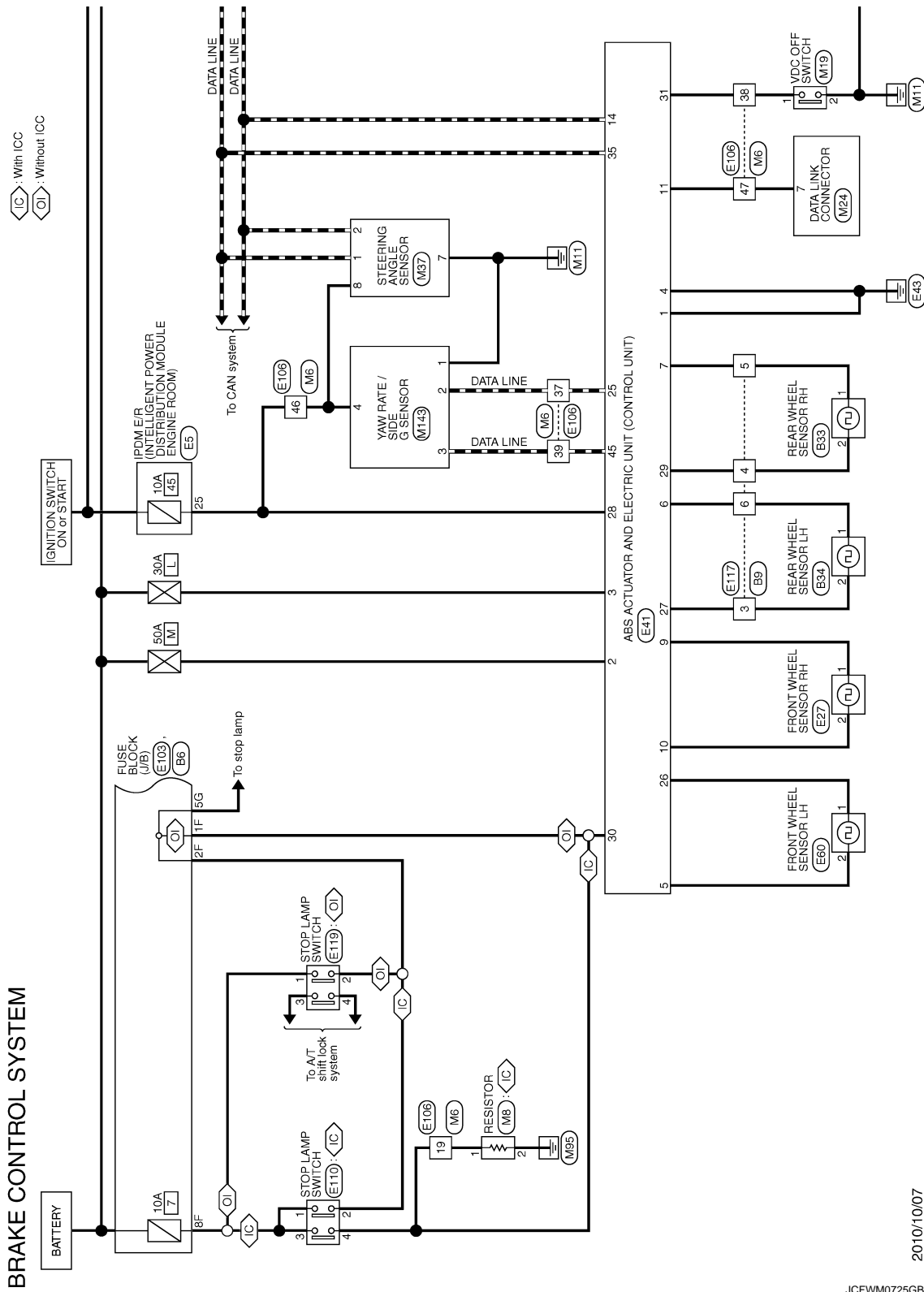

2010/10/07

JCFWM0725GB

ABS ACTUATOR AND ELECTRIC UNIT (CONTROL UNIT)

< ECU DIAGNOSIS INFORMATION >

[VDC/TCS/ABS]

A
B
C
D
E
BRC
G
H
I
J
K
L
M
N
O
P

⬠ : With AT
⬠ : With M/T

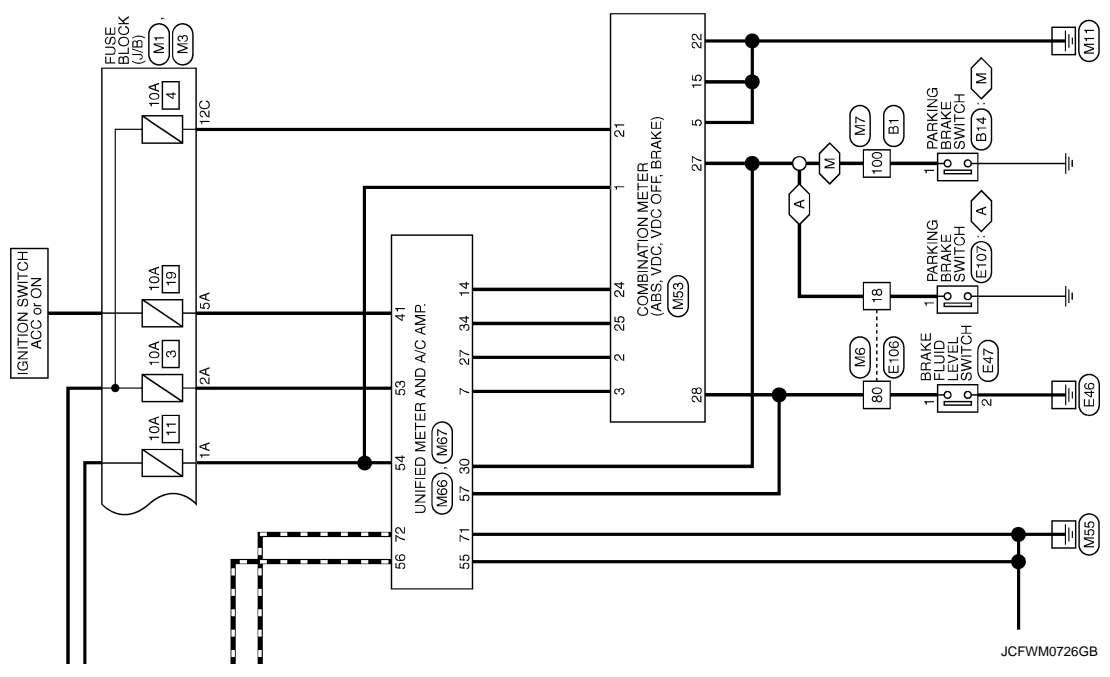

JCFWM0726GB

ABS ACTUATOR AND ELECTRIC UNIT (CONTROL UNIT)

< ECU DIAGNOSIS INFORMATION >

[VDC/TCS/ABS]

BRAKE CONTROL SYSTEM

Connector No.	B1
Connector Name	WIRE TO WIRE
Connector Type	TH80FV-CS16-TM4



Terminal No.	Color of Wire	Signal Name [Specification]
1	GR	
2	G	
3	SB	
4	Y	
6	Y	
15	V	
16	BR	
17	LG	
18	W	
20	L	
21	P	
22	L	
23	P	
24	GR	
25	SB	
26	G	
27	W	
28	G	
31	V	
32	SB	
33	SHIELD	
34	W	
35	BR	
36	Y	
37	SHIELD	
38	V	
39	LG	
40	P	
41	L	
42	SHIELD	
43	R	
44	G	
45	SHIELD	
46	SB	
49	L	
50	P	
55	P	
56	G	

56	V	
59	LG	
60	BR	
61	W	
62	R	
63	L	
64	Y	
65	SHIELD	
71	BR	
72	SB	
73	P	
74	L	
81	R	
82	B	
84	Y	
85	L	
86	GR	
87	R	
88	V	
90	GR	
91	Y	
95	EG	
96	R	
100	V	

Connector No.	B6
Connector Name	FUSE BLOCK (L/R)
Connector Type	NS12FBR-CS



Terminal No.	Color of Wire	Signal Name [Specification]
5G	LG	
6G	G	
10G	W	
11G	W	
12G	Y	

Connector No.	B9
Connector Name	WIRE TO WIRE
Connector Type	MM6FV-LC



Terminal No.	Color of Wire	Signal Name [Specification]
2	R	
3	GR	
4	LG	
5	BR	
6	EG	

Connector No.	B14
Connector Name	PARKING BRAKE SWITCH
Connector Type	P01FB-A



Terminal No.	Color of Wire	Signal Name [Specification]
1	V	

Connector No.	B33
Connector Name	REAR WHEEL SENSOR RH
Connector Type	FAZ02FB1



Terminal No.	Color of Wire	Signal Name [Specification]

1	BR	-
2	LG	-

Connector No.	B34
Connector Name	REAR WHEEL SENSOR LH
Connector Type	RH02FB



Terminal No.	Color of Wire	Signal Name [Specification]
1	BG	
2	GR	

ABS ACTUATOR AND ELECTRIC UNIT (CONTROL UNIT)

< ECU DIAGNOSIS INFORMATION >

[VDC/TCS/ABS]

A
B
C
D
E
BRC
G
H
I
J
K
L
M
N
O
P

BRAKE CONTROL SYSTEM

Connector No.	E5
Connector Name	ABS INFLUENT POWER DISTRIBUTION MODULE POWER POINT
Connector Type	TH20FY-GS2-M4-IV

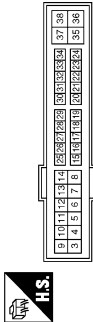

Terminal No.	Color of Wire	Signal Name [Specification]
4	V	-
5	L	-
6	SB	-
7	BR	-
11	BR	-
12	B/W	-
13	Y	-
16	LG	-
19	W	-
25	G	-
26	R	-
27	BG	-
28	L	-
30	GR	-
32	V	-
33	P	-
36	G	-

Connector No.	E27
Connector Name	FRONT WHEEL SENSOR RH
Connector Type	AJAZ2FB1



Terminal No.	Color of Wire	Signal Name [Specification]
1	B	-
2	W	-

Connector No.	E41
Connector Name	ABS ACTUATOR AND ELECTRIC UNIT (CONTROL UNIT)
Connector Type	BA44PE-AH24-LH

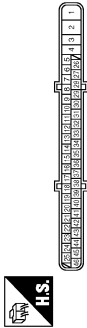

Terminal No.	Color of Wire	Signal Name [Specification]
1	B	GND
2	L	UBMR
3	R	UBVR
4	B	GND
5	Y	DS FL
6	BG	DP RL
7	BR	DP RR
9	B	DP FR
10	W	DS FR
11	V	DIAG-K
14	P	CAN-L
25	Y	BUS-L
26	LG	DP FL
27	GR	DS RL
28	G	UZ
29	P	DS RR
30	SB	BLS
31	R	VDC OFF SW
35	L	CAN-H
45	B	BUS-H

Connector No.	E47
Connector Name	BRAKE FLUID LEVEL SWITCH
Connector Type	YV02FGY



Terminal No.	Color of Wire	Signal Name [Specification]
1	W	-
2	B	-

Connector No.	E60
Connector Name	FRONT WHEEL SENSOR LH
Connector Type	AJAZ2FB1



Terminal No.	Color of Wire	Signal Name [Specification]
1	LG	-
2	Y	-

Connector No.	E103
Connector Name	FUSE BLOCK (J/B)
Connector Type	NS10FY-GS



Terminal No.	Color of Wire	Signal Name [Specification]
1F	SB	-
2F	V	-
4F	G	-
6F	BG	-
8F	L	-
9F	R	-

JCFWM0728GB

ABS ACTUATOR AND ELECTRIC UNIT (CONTROL UNIT)

< ECU DIAGNOSIS INFORMATION >

[VDC/TCS/ABS]

BRAKE CONTROL SYSTEM

Connector No.	E106
Connector Name	WIRE TO WIRE
Connector Type	TH88FW-CS16-TM4



Terminal No.	Color of Wire	Signal Name [Specification]
1	GR	-
3	BG	-
5	G	-
6	BG	-
7	V	- [With daytime running light]
7	LG	- [Without daytime running light]
9	R	- [With daytime running light]
10	W	- [Without daytime running light]
11	V	-
12	R	-
13	L	-
14	GR	-
15	P	-
16	W	-
17	V	-
18	BG	-
19	GR	-
20	LG	-
30	R	-
31	L	-
32	BG	-
33	P	-
34	V	-
35	BR	-
36	W	-
37	Y	-
38	R	-
39	B	-
40	G	-
41	W	-
42	LG	-
43	SB	-
44	GR	-
45	BG	-
46	LG	-
47	V	-
48	P	-

49	L	-
59	B	-
66	LG	-
67	SB	-
68	R	-
68	W	-
70	G	-
80	W	-
81	P	-
82	G	-
83	V	-
84	L	-
85	BG	-
86	LG	-
87	Y	-
88	GR	-
89	W	-
91	G	-
93	GR	-
95	Y	-
96	Y	-
97	BR	-
98	SHIELD	-
99	L	-
100	P	-

Connector No.	E107
Connector Name	PARKING BRAKE SWITCH
Connector Type	TB01FW



Terminal No.	Color of Wire	Signal Name [Specification]
1	BG	-

Connector No.	E110
Connector Name	STOP LAMP SWITCH
Connector Type	M04FW-LC



Terminal No.	Color of Wire	Signal Name [Specification]
1	L	-
2	V	-
3	L	-
4	SB	-

Connector No.	E117
Connector Name	WIRE TO WIRE
Connector Type	M08BW-LC



Terminal No.	Color of Wire	Signal Name [Specification]
2	L	-
3	GR	-
4	P	-
5	BR	-
6	BG	-

Connector No.	E119
Connector Name	STOP LAMP SWITCH
Connector Type	M04FW-LC



Terminal No.	Color of Wire	Signal Name [Specification]
1	L	-
2	V	-
3	Y	-
4	W	-

Connector No.	M1
Connector Name	FUSE BLOCK (J/B)
Connector Type	M508FW-M2



Terminal No.	Color of Wire	Signal Name [Specification]
1A	V	-
2A	G	-
3A	L	-
4A	P	-
5A	L	-
6A	Y	-
7A	R	-
8A	L	-

ABS ACTUATOR AND ELECTRIC UNIT (CONTROL UNIT)

< ECU DIAGNOSIS INFORMATION >

[VDC/TCS/ABS]

BRAKE CONTROL SYSTEM

Connector No.	M3
Connector Name	FUSE BLOCK (J/B)
Connector Type	INS12FY-CS

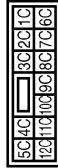

Terminal No.	Color of Wire	Signal Name [Specification]
6C	SB	-
7C	B	-
8C	W	-
9C	BG	-
10C	L	- [With A/T]
11C	LG	- [With M/T]
12C	G	-

Connector No.	M6
Connector Name	WIRE TO WIRE
Connector Type	TH80MW-CS16-TM4

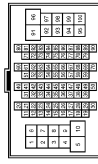

Terminal No.	Color of Wire	Signal Name [Specification]
1	BG	-
3	R	-
5	G	-
6	LG	-
7	W	-
9	G	-
10	W	-
11	V	-
12	R	-
13	L	-
14	GR	-
15	P	-
16	W	-
17	BR	-
18	P	-

Connector No.	M7
Connector Name	WIRE TO WIRE
Connector Type	TH80MW-CS16-TM4



Terminal No.	Color of Wire	Signal Name [Specification]
1	GR	-
2	P	-
3	SB	- [With automatic drive positioner]
3	P	- [Without automatic drive positioner]
4	Y	-
6	L	-
15	R	-
16	BR	-
17	P	-
18	V	-
20	L	-
21	P	-
22	L	-
23	P	-
24	V	-
25	LG	-
26	BR	-
27	BG	-
28	LG	-
31	V	-
32	LG	-
33	SHIELD	-
34	GR	-
35	BR	-
36	Y	-
37	SHIELD	-
38	SB	-
39	LG	-
40	O	-
41	W	-
42	SHIELD	-
43	R	-
44	G	-
45	SHIELD	-
46	SB	-
49	L	-
50	P	-
55	W	-

56	B	-
58	V	-
59	Y	-
60	Y	-
61	W	-
62	R	-
63	G	-
64	B	-
65	SHIELD	-
71	V	-
72	P	-
73	SB	-
74	V	-
81	W	-
82	BR	-
84	LG	-
85	BG	-
86	SB	-
87	G	-
88	GR	-
90	P	-
91	BG	-
95	BG	-
96	Y	-
100	P	-

Connector No.	M8
Connector Name	RESISTOR
Connector Type	M02FBR-LC



Terminal No.	Color of Wire	Signal Name [Specification]
1	L	-
2	B	-

JCFWM0730GB

A
B
C
D
E
BRC
G
H
I
J
K
L
M
N
O
P

ABS ACTUATOR AND ELECTRIC UNIT (CONTROL UNIT)

< ECU DIAGNOSIS INFORMATION >

[VDC/TCS/ABS]

BRAKE CONTROL SYSTEM

Connector No.	M19
Connector Name	VDC OFF SWITCH
Connector Type	TK08FCY



Terminal No.	Color of Wire	Signal Name [Specification]
1	R	-
2	B	-
3	SB	-
4	B	-

Connector No.	M24
Connector Name	DATA LINK CONNECTOR
Connector Type	BD18FV-P

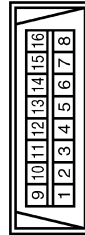

Terminal No.	Color of Wire	Signal Name [Specification]
3	LG	-
4	B	-
5	B	-
6	L	-
7	V	-
8	G	-
11	SB	-
14	P	-
16	R	-

Connector No.	M37
Connector Name	STEERING ANGLE SENSOR
Connector Type	TH08FV-NH

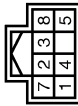

Terminal No.	Color of Wire	Signal Name [Specification]
1	L	CAN-H
2	B	CAN-L
7	B	GND
8	G	IGN

Connector No.	M53
Connector Name	COMBINATION METER
Connector Type	SAB40FV



Terminal No.	Color of Wire	Signal Name [Specification]
1	V	BATTERY POWER SUPPLY
2	LG	COMMUNICATION SIGNAL (METER->AMP.)
3	GR	COMMUNICATION SIGNAL (AMP->METER)
5	B	GROUND
6	W	ALTERNATOR SIGNAL
7	LG	AIR BAG SIGNAL
10	W	SECURITY SIGNAL
15	B	GROUND
16	BR	METER CONTROL SWITCH GROUND
18	GR	ILL GND
19	B	ILL GND
20	R	ILL
21	G	IGNITION SIGNAL
22	B	GROUND
24	BR	COMMUNICATION SIGNAL (LTD->AMP.)
25	Y	COMMUNICATION SIGNAL (AMP->LTD)
26	R	VEHICLE SPEED SIGNAL (8-PULSE)
27	P	PARKING BRAKE SWITCH SIGNAL

28	SB	BRAKE FLUID LEVEL SWITCH
29	P	SEAT BELT BUCKLE SW SIGNAL (DRIVER SIDE)
30	G	SEAT BELT BUCKLE SWITCH SIGNAL (PASSENGER SIDE)
31	L	WASHER LEVEL SWITCH SIGNAL
32	R	ILLUMINATION CONTROL SIGNAL
36	LG	SELECT SWITCH SIGNAL
37	Y	ENTER SWITCH SIGNAL
38	G	TRIP A/B RESET SWITCH SIGNAL
39	P	ILLUMINATION CONTROL SWITCH SIGNAL (-)
40	BG	ILLUMINATION CONTROL SWITCH SIGNAL (+)

Connector No.	M66
Connector Name	UNIFIED METER AND A/C AMP.
Connector Type	TH40FV-NH



Terminal No.	Color of Wire	Signal Name [Specification]
4	G	STOP LAMP SWITCH SIGNAL
5	L	MANUAL MODE SHIFTER UP SIGNAL
6	BG	PADDLE SHIFTER UP SIGNAL
7	GR	COMMUNICATION SIGNAL (AMP->METER)
8	L	VEHICLE SPEED SIGNAL (2-PULSE)
9	SB	SEAT BELT BUCKLE SWITCH SIGNAL (DRIVER SIDE)
10	W	MANUAL MODE SIGNAL
11	G	NON-MANUAL MODE SIGNAL
14	BR	COMMUNICATION SIGNAL (LTD->AMP.)
20	BR	ION ON / OFF SIGNAL
23	Y	AT SNOW SWITCH SIGNAL
25	V	MANUAL MODE SHIFTER DOWN SIGNAL
26	G	PADDLE SHIFTER DOWN SIGNAL
27	LG	COMMUNICATION SIGNAL (METER->AMP.)
28	R	VEHICLE SPEED SIGNAL (8-PULSE)
30	V	PARKING BRAKE SWITCH SIGNAL
34	Y	COMMUNICATION SIGNAL (AMP->LTD)
38	P	BLOWER MOTOR CONTROL SIGNAL

Connector No.	M67
Connector Name	UNIFIED METER AND A/C AMP.
Connector Type	TH52FV-NH



Terminal No.	Color of Wire	Signal Name [Specification]
41	L	ACC POWER SUPPLY
42	BR	FUEL LEVEL SENSOR SIGNAL
43	BR	INTAKE SENSOR SIGNAL
44	LG	IN-VEHICLE SENSOR SIGNAL
45	V	AMBIENT SENSOR SIGNAL
46	Y	SUNLOAD SENSOR SIGNAL
47	G	EXHAUST GASE ORIGNAL (DOWN DETECTING SENSOR SIGNAL)
53	W	IGNITION POWER SUPPLY
54	SB	BATTERY POWER SUPPLY
55	B	GROUND
56	L	CAN-H
57	LG	BRAKE FLUID LEVEL SWITCH
58	Y	FUEL LEVEL SENSOR GROUND
59	GR	INTAKE SENSOR GROUND
60	W	IN-VEHICLE SENSOR GROUND
61	B	AMBIENT SENSOR GROUND
62	SB	SUNLOAD SENSOR GROUND
63	L	ION CONTROL MODE OUTPUT SIGNAL
65	BG	ECV SIGNAL
69	P	A/C LAN SIGNAL
70	R	EACH DOOR MOTOR POWER SUPPLY
71	GR	GROUND
72	P	CAN-L

ABS ACTUATOR AND ELECTRIC UNIT (CONTROL UNIT)

< ECU DIAGNOSIS INFORMATION >

[VDC/TCS/ABS]

A
B
C
D
E
G
H
I
J
K
L
M
N
O
P

BRC

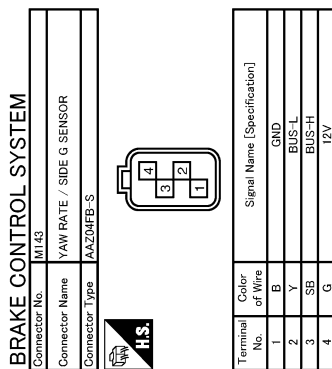

JCFWM0732GB

INFOID:000000006450593

Fail-Safe

ABS, EBD SYSTEM

If ABS malfunction electrically, ABS warning lamp, VDC warning lamp will turn on. If EBD malfunction electrically, brake warning lamp, ABS warning lamp, VDC warning lamp will turn on. Simultaneously, the VDC/TCS/ABS become one of the following conditions of the fail-safe function.

ABS ACTUATOR AND ELECTRIC UNIT (CONTROL UNIT)

[VDC/TCS/ABS]

< ECU DIAGNOSIS INFORMATION >

- For malfunction of ABS, only the EBD is activated and the condition of vehicle is the same condition of vehicles without TCS/ABS system.

NOTE:

ABS self-diagnosis sound may be heard. That is a normal condition because a self-diagnosis for "Ignition switch ON" and "The first starting" are being performed.

- For malfunction of EBD, EBD and ABS become inoperative, and the condition of vehicle is the same as the condition of vehicles without TCS/ABS, EBD system.

VDC / TCS

If VDC/TCS/ABS system malfunction electrically, VDC warning lamp are turned on, and the condition of vehicle is the same as the condition of vehicles without VDC/TCS control.

CAUTION:

If the Fail-Safe function is activated, then perform self-diagnosis for "ABS" with CONSULT-III.

DTC No. Index

INFOID:000000006450594

DTC	Items (CONSULT screen terms)	Reference
C1101	RR RH SENSOR-1	BRC-32, "DTC Logic"
C1102	RR LH SENSOR-1	
C1103	FR RH SENSOR-1	
C1104	FR LH SENSOR-1	
C1105	RR RH SENSOR-2	BRC-35, "DTC Logic"
C1106	RR LH SENSOR-2	
C1107	FR RH SENSOR-2	
C1108	FR LH SENSOR-2	
C1109	BATTERY VOLTAGE [ABNORMAL]	BRC-40, "DTC Logic"
C1110	CONTROLLER FAILURE	BRC-42, "DTC Logic"
C1111	PUMP MOTOR	BRC-43, "DTC Logic"
C1115	ABS SENSOR [ABNORMAL SIGNAL]	BRC-45, "DTC Logic"
C1116	STOP LAMP SW	BRC-50, "DTC Logic"
C1120	FR LH IN ABS SOL	BRC-55, "DTC Logic"
C1121	FR LH OUT ABS SOL	BRC-57, "DTC Logic"
C1122	FR RH IN ABS SOL	BRC-55, "DTC Logic"
C1123	FR RH OUT ABS SOL	BRC-57, "DTC Logic"
C1124	RR LH IN ABS SOL	BRC-55, "DTC Logic"
C1125	RR LH OUT ABS SOL	BRC-57, "DTC Logic"
C1126	RR RH IN ABS SOL	BRC-55, "DTC Logic"
C1127	RR RH OUT ABS SOL	BRC-57, "DTC Logic"
C1130	ENGINE SIGNAL 1	BRC-59, "DTC Logic"
C1131	ENGINE SIGNAL 2	
C1132	ENGINE SIGNAL 3	
C1138	4WAS CIRCUIT	BRC-60, "DTC Logic"
C1140	ACTUATOR RLY	BRC-61, "DTC Logic"
C1142	PRESS SEN CIRCUIT	BRC-63, "DTC Logic"
C1143	ST ANG SEN CIRCUIT	BRC-65, "DTC Logic"
C1144	ST ANG SEN SIGNAL	BRC-67, "DTC Logic"
C1145	YAW RATE SENSOR	BRC-68, "DTC Logic"
C1146	SIDE G-SEN CIRCUIT	

ABS ACTUATOR AND ELECTRIC UNIT (CONTROL UNIT)

< ECU DIAGNOSIS INFORMATION >

[VDC/TCS/ABS]

DTC	Items (CONSULT screen terms)	Reference
C1147	USV LINE [FL-RR]	BRC-71, "DTC Logic"
C1148	USV LINE [FR-RL]	
C1149	HSV LINE [FL-RR]	
C1150	HSV LINE [FR-RL]	
C1153	EMERGENCY BRAKE	BRC-42, "DTC Logic"
C1155	BR FLUID LEVEL LOW	BRC-73, "DTC Logic"
C1170	VARIANT CORDING	BRC-42, "DTC Logic"
C1185	ACC CONT	BRC-76, "DTC Logic"
U1000	CAN COMM CIRCUIT	BRC-77, "DTC Logic"
U1002	SYSTEM COMM (CAN)	BRC-78, "DTC Logic"

A
B
C
D
E

BRC

G
H
I
J
K
L
M
N
O
P

SYMPTOM DIAGNOSIS

EXCESSIVE ABS FUNCTION OPERATION FREQUENCY

Diagnosis Procedure

INFOID:000000006450595

1. CHECK START

Check front and rear brake force distribution using a brake tester. Refer to [BR-64. "General Specifications"](#).

Is the inspection result normal?

YES >> GO TO 2.

NO >> Check brake system.

2. CHECK FRONT AND REAR AXLE

Make sure that there is no excessive play in the front and rear axles.

- Front
 - 2WD: refer to [FAX-7. "Inspection"](#).
 - AWD: refer to [FAX-16. "Inspection"](#).
- Rear: refer to [RAX-5. "Inspection"](#).

Is the inspection result normal?

YES >> GO TO 3.

NO >> Repair or replace malfunctioning components.

3. CHECK WHEEL SENSOR AND SENSOR ROTOR

Check the following.

- Wheel sensor installation for damage.
- Sensor rotor installation for damage.
- Wheel sensor connector connection.
- Wheel sensor harness inspection.

Is the inspection result normal?

YES >> GO TO 4.

NO >>

- Replace wheel sensor or sensor rotor.
- Repair harness.

4. CHECK ABS WARNING LAMP DISPLAY

Make sure that the ABS warning lamp is turned off after the ignition switch is turned ON or when driving.

Is the ABS warning lamp illuminated?

YES >> Perform self-diagnosis for "ABS" with CONSULT-III.

NO >> Normal

UNEXPECTED PEDAL REACTION

< SYMPTOM DIAGNOSIS >

[VDC/TCS/ABS]

UNEXPECTED PEDAL REACTION

Diagnosis Procedure

INFOID:000000006450596

1.CHECK BRAKE PEDAL STROKE

Check brake pedal stroke. Refer to [BR-7, "Inspection and Adjustment"](#).

Is the stroke too large?

- YES >>
- Bleed air from brake tube and hose. Refer to [BR-11, "Bleeding Brake System"](#).
 - Check brake pedal, brake booster, and master cylinder for mount play, looseness, brake system fluid leakage, etc.
 - Brake pedal: Refer to [BR-7, "Inspection and Adjustment"](#).
 - Brake master cylinder: Refer to [BR-12, "Inspection"](#).
 - Brake booster: Refer to [BR-13, "Inspection"](#).
 - Brake fluid: Refer to [BR-10, "Inspection"](#).

NO >> GO TO 2.

2.CHECK FUNCTION

Disconnect ABS actuator and electric unit (control unit) connector to deactivate ABS. Check if braking force is normal in this condition. Connect connector after inspection.

Is the inspection result normal?

- YES >> Normal
NO >> Check brake system.

A
B
C
D
E
BRC
G
H
I
J
K
L
M
N
O
P

THE BRAKING DISTANCE IS LONG

< SYMPTOM DIAGNOSIS >

[VDC/TCS/ABS]

THE BRAKING DISTANCE IS LONG

Diagnosis Procedure

INFOID:000000006450597

CAUTION:

The stopping distance on slippery road surfaces might be longer when the ABS is operating than when the ABS is not operating.

1. CHECK FUNCTION

Turn ignition switch OFF and disconnect ABS actuator and electric unit (control unit) connector to deactivate ABS. In this condition, check stopping distance. After inspection, connect connector.

Is the inspection result normal?

YES >> Normal

NO >> Check brake system.

ABS FUNCTION DOES NOT OPERATE

< SYMPTOM DIAGNOSIS >

[VDC/TCS/ABS]

ABS FUNCTION DOES NOT OPERATE

Diagnosis Procedure

INFOID:000000006450598

CAUTION:

ABS does not operate when speed is 10 km/h (6 MPH) or lower.

1.CHECK ABS WARNING LAMP DISPLAY

Make sure that the ABS warning lamp turns OFF after ignition switch is turned ON or when driving.

Is the inspection result normal?

YES >> Normal

NO >> Perform self-diagnosis for "ABS" with CONSULT-III.

A
B
C
D
E
G
H
I
J
K
L
M
N
O
P

BRC

PEDAL VIBRATION OR ABS OPERATION SOUND OCCURS

< SYMPTOM DIAGNOSIS >

[VDC/TCS/ABS]

PEDAL VIBRATION OR ABS OPERATION SOUND OCCURS

Diagnosis Procedure

INFOID:000000006450599

CAUTION:

Under the following conditions, ABS is activated and vibration is felt when brake pedal is lightly depressed (just place a foot on it). However, this is normal.

- When shifting gears
- When driving on slippery road
- During cornering at high speed
- When passing over bumps or grooves [at approximately 50 mm (1.97 in) or more]
- When pulling away just after starting engine [at approximately 10 km/h (6 MPH) or higher]

1. SYMPTOM CHECK 1

Check that there are pedal vibrations when the engine is started.

Do vibrations occur?

- YES >> GO TO 2.
- NO >> Inspect the brake pedal.

2. SYMPTOM CHECK 2

Check that there are ABS operation noises when the engine is started.

Do the operation noises occur?

- YES >> GO TO 3.
- NO >> Perform self-diagnosis for "ABS" with CONSULT-III.

3. SYMPTOM CHECK 3

Check symptoms when electrical component (headlamps, etc.) switches are operated.

Do symptoms occur?

- YES >> Check if there is a radio, antenna, antenna lead wire, or wiring close to the control unit. If there is, move it farther away.
- NO >> Normal

VEHICLE JERKS DURING VDC/TCS/ABS CONTROL

< SYMPTOM DIAGNOSIS >

[VDC/TCS/ABS]

VEHICLE JERKS DURING VDC/TCS/ABS CONTROL

Diagnosis Procedure

INFOID:000000006450600

1.SYMPTOM CHECK

Check if the vehicle jerks during VDC/TCS/ABS control.

Is the inspection result normal?

- YES >> Normal.
- NO >> GO TO 2.

2.CHECK SELF-DIAGNOSIS RESULTS

Perform self-diagnosis for "ABS" with CONSULT-III.

Are self-diagnosis results indicated?

- YES >> Check corresponding items, make repairs, and perform self-diagnosis for "ABS" with CONSULT-III.
- NO >> GO TO 3.

3.CHECK CONNECTOR

1. Turn ignition switch OFF and disconnect ABS actuator and electric unit (control unit) connector and check terminal for deformation, disconnection, looseness, etc.
2. Securely connect connectors and perform self-diagnosis for "ABS" with CONSULT-III.

Are self-diagnosis results indicated?

- YES >> If poor contact, damage, open or short circuit of connector terminal is found, repair or replace.
- NO >> GO TO 4.

4.CHECK ECM AND TCM SELF-DIAGNOSIS RESULTS

Perform self-diagnosis for "ENGINE" and "TRANSMISSION" with CONSULT-III.

Are self-diagnosis results indicated?

- YES >> Check the corresponding items.
- NO >> Replace ABS actuator and electric unit (control unit).

A
B
C
D
E
G
H
I
J
K
L
M
N
O
P

BRC

NORMAL OPERATING CONDITION

< SYMPTOM DIAGNOSIS >

[VDC/TCS/ABS]

NORMAL OPERATING CONDITION

Description

INFOID:000000006450601

Symptom	Result
Slight vibrations are felt on the brake pedal and the operation noises occur, when VDC, TCS or ABS is activated.	This is a normal condition due to the VDC, TCS or ABS activation.
Stopping distance is longer than that of vehicles without ABS when the vehicle drives on rough, gravel, or snow-covered (fresh, deep snow) roads.	
The brake pedal moves and generates noises, when TCS or VDC is activated due to rapid acceleration or sharp turn.	
The brake pedal vibrates and motor operation noises occur from the engine room, after the engine starts and just after the vehicle starts.	This is a normal, and it is caused by the ABS operation check.
Depending on the road conditions, the driver may experience a sluggish feel.	This is normal, because TCS places the highest priority on the optimum traction (stability).
TCS may activate momentarily if wheel speed changes when driving over location where friction coefficient varies, when downshifting, or when fully depressing accelerator pedal.	
The ABS warning lamp and VDC warning lamp may turn ON when the vehicle is subject to strong shaking or large vibration, such as when the vehicle is rotating on a turntable or located on a ship while the engine is running.	In this case, restart the engine on a normal road. If the normal condition is restored, there is no malfunction. At that time, erase the self-diagnosis memory.
VDC may not operate normally or the ABS warning lamp and VDC warning lamp may illuminate, when running on a special road that is extremely slanted (e.g. bank in a circuit course).	
A malfunction may occur in the yaw rate/side G sensor system, when the vehicle turns sharply, such as during a spin turn, axle turn, or drift driving, while the VDC function is off (VDC warning lamp illuminated).	
The vehicle speed will not increase even though the accelerator pedal is depressed, when inspecting the speedometer on a 2-wheel chassis dynamometer.	Normal (Deactivate the VDC/TCS function before performing an inspection on a chassis dynamometer.)
VDC warning lamp may simultaneously turn on when low tire pressure warning lamp turns on.	This is not a VDC system error but results from characteristic change of tire.

PRECAUTION

PRECAUTIONS

Precaution for Supplemental Restraint System (SRS) "AIR BAG" and "SEAT BELT PRE-TENSIONER"

INFOID:000000006450602

The Supplemental Restraint System such as "AIR BAG" and "SEAT BELT PRE-TENSIONER", used along with a front seat belt, helps to reduce the risk or severity of injury to the driver and front passenger for certain types of collision. This system includes seat belt switch inputs and dual stage front air bag modules. The SRS system uses the seat belt switches to determine the front air bag deployment, and may only deploy one front air bag, depending on the severity of a collision and whether the front occupants are belted or unbelted. Information necessary to service the system safely is included in the "SRS AIR BAG" and "SEAT BELT" of this Service Manual.

WARNING:

Always observe the following items for preventing accidental activation.

- To avoid rendering the SRS inoperative, which could increase the risk of personal injury or death in the event of a collision that would result in air bag inflation, all maintenance must be performed by an authorized NISSAN/INFINITI dealer.
- Improper maintenance, including incorrect removal and installation of the SRS, can lead to personal injury caused by unintentional activation of the system. For removal of Spiral Cable and Air Bag Module, see "SRS AIR BAG".
- Never use electrical test equipment on any circuit related to the SRS unless instructed to in this Service Manual. SRS wiring harnesses can be identified by yellow and/or orange harnesses or harness connectors.

PRECAUTIONS WHEN USING POWER TOOLS (AIR OR ELECTRIC) AND HAMMERS

WARNING:

Always observe the following items for preventing accidental activation.

- When working near the Air Bag Diagnosis Sensor Unit or other Air Bag System sensors with the ignition ON or engine running, never use air or electric power tools or strike near the sensor(s) with a hammer. Heavy vibration could activate the sensor(s) and deploy the air bag(s), possibly causing serious injury.
- When using air or electric power tools or hammers, always switch the ignition OFF, disconnect the battery, and wait at least 3 minutes before performing any service.

Precautions Necessary for Steering Wheel Rotation After Battery Disconnection

INFOID:000000006450603

CAUTION:

Comply with the following cautions to prevent any error and malfunction.

- Before removing and installing any control units, first turn the ignition switch to the LOCK position, then disconnect both battery cables.
- After finishing work, confirm that all control unit connectors are connected properly, then re-connect both battery cables.
- Always use CONSULT to perform self-diagnosis as a part of each function inspection after finishing work. If a DTC is detected, perform trouble diagnosis according to self-diagnosis results.

For vehicle with steering lock unit, if the battery is disconnected or discharged, the steering wheel will lock and cannot be turned.

If turning the steering wheel is required with the battery disconnected or discharged, follow the operation procedure below before starting the repair operation.

OPERATION PROCEDURE

1. Connect both battery cables.

NOTE:

Supply power using jumper cables if battery is discharged.

2. Turn the ignition switch to ACC position.
(At this time, the steering lock will be released.)
3. Disconnect both battery cables. The steering lock will remain released with both battery cables disconnected and the steering wheel can be turned.

A
B
C
D
E
BRC
G
H
I
J
K
L
M
N
O
P

PRECAUTIONS

[VDC/TCS/ABS]

< PRECAUTION >

4. Perform the necessary repair operation.
5. When the repair work is completed, re-connect both battery cables. With the brake pedal released, turn the ignition switch from ACC position to ON position, then to LOCK position. (The steering wheel will lock when the ignition switch is turned to LOCK position.)
6. Perform self-diagnosis check of all control units using CONSULT.

Precaution for Procedure without Cowl Top Cover

INFOID:000000006450604

When performing the procedure after removing cowl top cover, cover the lower end of windshield with urethane, etc to prevent damage to windshield.

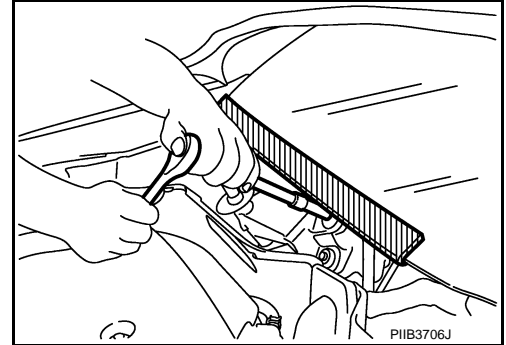

Precaution for Brake System

INFOID:000000006450605

WARNING:

Clean brake pads and shoes with a waste cloth, then wipe with a dust collector.

- Brake fluid use refer to [MA-11, "Fluids and Lubricants"](#).
- Never reuse drained brake fluid.
- Never spill or splash brake fluid on painted surfaces. Brake fluid may seriously damage paint. Wipe it off immediately and wash with water if it gets on a painted surface.
- Never use mineral oils such as gasoline or light oil. They may damage rubber parts and cause improper operation.
- Always loosen the brake tube flare nut with a flare nut wrench.
- Tighten the brake tube flare nut to the specified torque with a crow-foot (A) and torque wrench (B).
- Always conform the specified tightening torque when installing the brake pipes.
- Brake system is an important safety part. If a brake fluid leak is detected, always disassemble the affected part. If a malfunction is detected, replace part with a new one.
- Turn the ignition switch OFF and disconnect the ABS actuator and electric unit (control unit) connector or the battery negative terminal before performing the work.

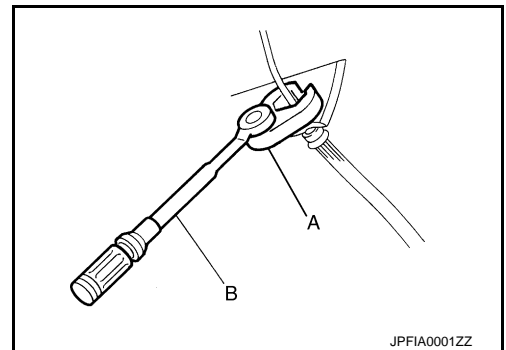

Precaution for Brake Control

INFOID:000000006450606

- When starting engine or when starting vehicle just after starting engine, brake pedal may vibrate or motor operating noise may be heard from engine compartment. This is normal condition.
- When an error is indicated by ABS or another warning lamp, collect all necessary information from customer (what symptoms are present under what conditions) and check for estimate causes before starting diagnostic servicing. Besides electrical system inspection, check brake booster operation, brake fluid level, and oil leaks.
- If tire size and type are used in an improper combination, or brake pads are not Genuine NISSAN parts, stopping distance or steering stability may deteriorate.
- ABS might be out of order or malfunctions by putting a radio (wiring inclusive), an antenna and a lead-in wire near the control unit.
- VDC system may not operate normally or a VDC warning lamp may light.
- When replacing the following parts with parts other than genuine parts or making modifications: Suspension related parts (shock absorber, spring, bushing, etc.), tires, wheels (other than specified sizes), brake-related parts (pad, rotor, caliper, etc.), engine-related parts (muffler, ECM, etc.) and body reinforcement-related parts (roll bar, tower bar, etc.).
- When driving with worn or deteriorated suspension, tires and brake-related parts.

PRECAUTIONS

< PRECAUTION >

[VDC/TCS/ABS]

Precautions for Harness Repair

INFOID:000000006450607

COMMUNICATION LINE

- Solder the repaired area and wrap tape around the soldered area.

NOTE:

A fray of twisted lines must be within 110 mm (4.33 in).

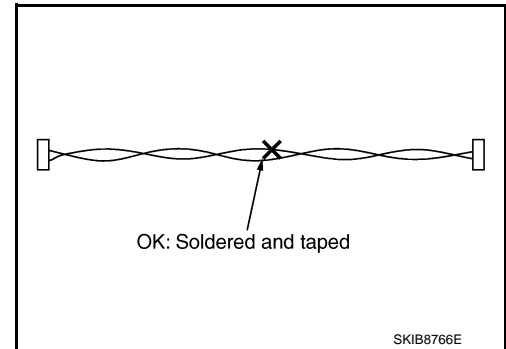

- Bypass connection is never allowed at the repaired area.

NOTE:

Bypass connection may cause communication error as spliced wires that are separate from the main line or twisted lines lose noise immunity.

- Replace the applicable harness as an assembly if error is detected on the shield lines of communication line.

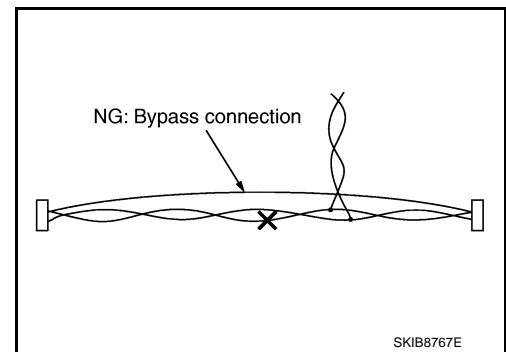

A
B
C
D
E
BRC
G
H
I
J
K
L
M
N
O
P

PREPARATION

< PREPARATION >

[VDC/TCS/ABS]

PREPARATION

PREPARATION

Special Service Tool

INFOID:000000006450608

The actual shapes of Kent-Moore tools may differ from those of special service tools illustrated here.

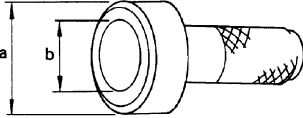
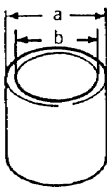
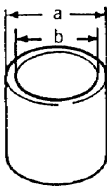
Tool number (Kent-Moore No.) Tool name		Description
ST30720000 (J-25405) Drift a: 77 mm (3.03 in) dia. b: 55.5 mm (2.185 in) dia.	 <p style="text-align: center; font-size: small;">ZZA0701D</p>	Installing rear sensor rotor
ST27863000 (—) Drift a: 74.5 mm (2.933 in) dia. b: 62.5 mm (2.461 in) dia.	 <p style="text-align: center; font-size: small;">ZZA0832D</p>	
KV40104710 (—) a: 76.3 mm (3.004 in) dia. b: 67.9 mm (2.673 in) dia.	 <p style="text-align: center; font-size: small;">ZZA0832D</p>	

Commercial Service Tool

INFOID:000000006450609

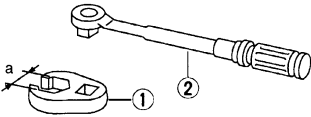
Tool name		Description
1. Flare nut crowfoot a: 10 mm (0.39 in) /12 mm (0.47 in) 2. Torque wrench	 <p style="text-align: center; font-size: small;">S-NT360</p>	Installing brake tube

WHEEL SENSOR

< REMOVAL AND INSTALLATION >

[VDC/TCS/ABS]

REMOVAL AND INSTALLATION

WHEEL SENSOR

Exploded View

INFOID:000000006450610

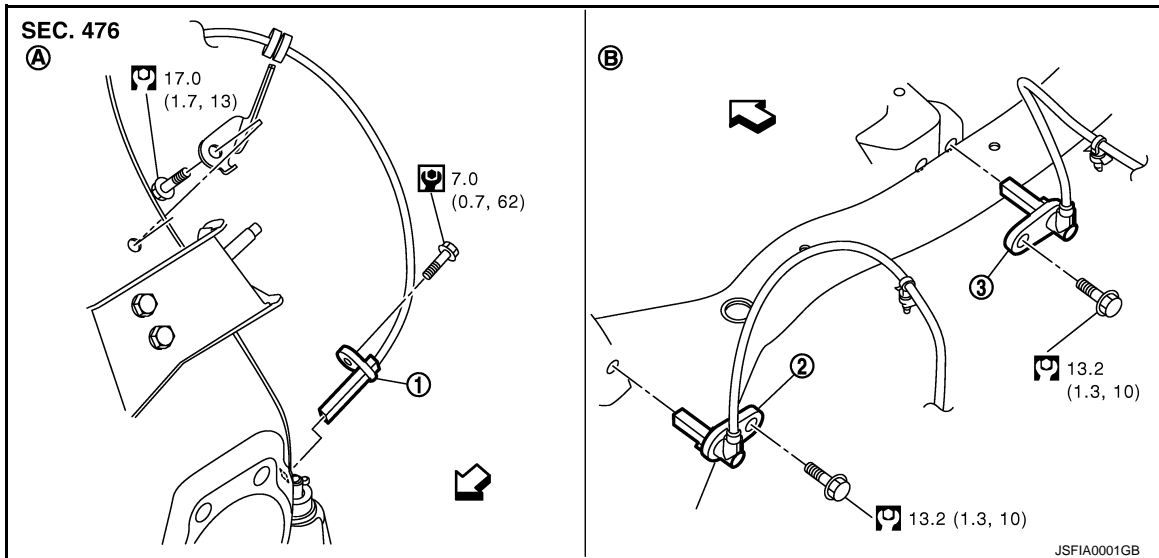

1. Front LH wheel sensor

2. Rear LH wheel sensor

3. Rear RH wheel sensor

A. Front

B. Rear

↔: Vehicle front

Refer to [GI-4, "Components"](#) for symbol marks in the figure.

NOTE:

The above figure (front side) shows left side. Right side is the mirror image.

Removal and Installation

INFOID:000000006450611

REMOVAL

Pay attention to the following when removing sensor.

CAUTION:

- Do not twist sensor harness as much as possible, when removing it. Pull sensors out without pulling sensor harness.
- Take care to avoid damaging sensor edges or rotor teeth. Remove wheel sensor first before removing front or rear wheel hub. This is to avoid damage to sensor wiring and loss of sensor function.

INSTALLATION

Pay attention to the following when installing wheel sensor. Tighten installation bolts to the specified torques.

- When installing, make sure there is no foreign material such as iron chips on and in the mounting hole of the wheel sensor. Make sure no foreign material has been caught in the sensor rotor. Remove any foreign material and clean the mount.
- When installing wheel sensor, be sure to press rubber grommets in until they lock at locations shown above in the figure. When installed, harness must not be twisted.

SENSOR ROTOR

[VDC/TCS/ABS]

< REMOVAL AND INSTALLATION >

SENSOR ROTOR

FRONT SENSOR ROTOR

FRONT SENSOR ROTOR : Exploded View

INFOID:000000006450612

Refer to [FAX-8, "Exploded View"](#) (2WD models), [FAX-18, "Exploded View"](#) (AWD models).

FRONT SENSOR ROTOR : Removal and Installation

INFOID:000000006450613

REMOVAL

Sensor rotor cannot be disassembled. Remove the sensor rotor together with hub bearing assembly. Refer to [FAX-8, "Exploded View"](#) (2WD models), [FAX-18, "Exploded View"](#) (AWD models).

INSTALLATION

Sensor rotor cannot be disassembled. Remove the sensor rotor together with hub bearing assembly. Refer to [FAX-8, "Exploded View"](#) (2WD models), [FAX-18, "Exploded View"](#) (AWD models).

REAR SENSOR ROTOR

REAR SENSOR ROTOR : Exploded View

INFOID:000000006450614

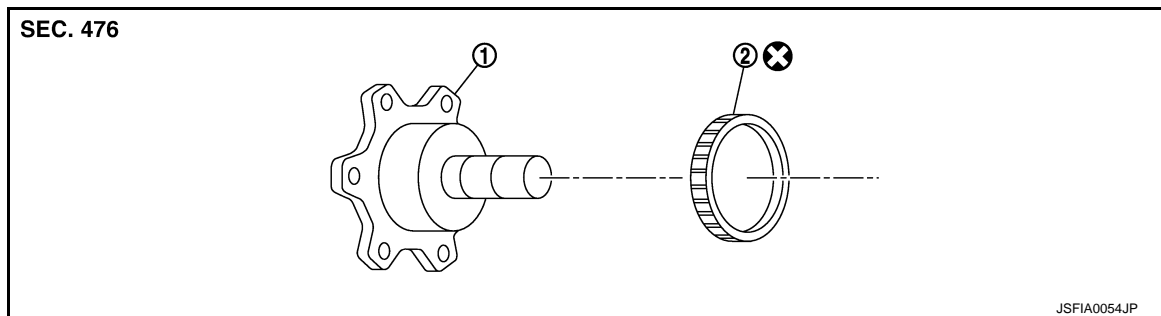

1. Side flange
2. Rear wheel sensor rotor

Refer to [GI-4, "Components"](#) for symbol marks in the figure.

REAR SENSOR ROTOR : Removal and Installation

INFOID:000000006450615

REMOVAL

- Follow the procedure below to remove rear sensor rotor.
- Remove side flange. Refer to [DLN-183, "2WD : Exploded View"](#) (R200: 2WD models), [DLN-196, "AWD : Exploded View"](#) (R200: AWD models), [DLN-265, "2WD \(M/T\) : Exploded View"](#) [R200V: M/T (2WD) models], [DLN-277, "2WD \(A/T\) : Exploded View"](#) [R200V: A/T (2WD) models], [DLN-290, "AWD : Exploded View"](#) (R200V: AWD models).
- Using a bearing replacer (suitable tool) and puller (suitable tool), remove sensor rotor from side flange.

INSTALLATION

CAUTION:

Do not reuse sensor rotor.

- Follow the procedure below to install rear sensor rotor.
- Using a drifts, press rear sensor rotor onto side flange.

A: Drift [SST: ST30720000 (J-25405)]

B: Drift [SST: ST27863000 (—)]

C: Drift [SST: KV40104710 (—)]

- Install side flange. Refer to [DLN-183, "2WD : Exploded View"](#) (R200: 2WD models), [DLN-196, "AWD : Exploded View"](#) (R200: AWD models), [DLN-265, "2WD \(M/T\) : Exploded View"](#) [R200V: M/

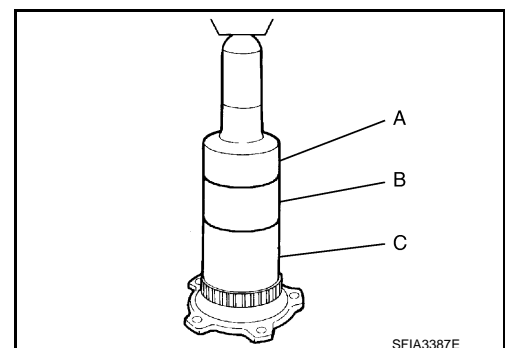

SENSOR ROTOR

< REMOVAL AND INSTALLATION >

[VDC/TCS/ABS]

T (2WD) models], [DLN-277. "2WD \(A/T\) : Exploded View"](#) [R200V: A/T (2WD) models], [DLN-290. "AWD : Exploded View"](#) (R200V: AWD models).

- A
- B
- C
- D
- E
- BRC**
- G
- H
- I
- J
- K
- L
- M
- N
- O
- P

ABS ACTUATOR AND ELECTRIC UNIT (CONTROL UNIT)

< REMOVAL AND INSTALLATION >

[VDC/TCS/ABS]

ABS ACTUATOR AND ELECTRIC UNIT (CONTROL UNIT)

Exploded View

INFOID:000000006450616

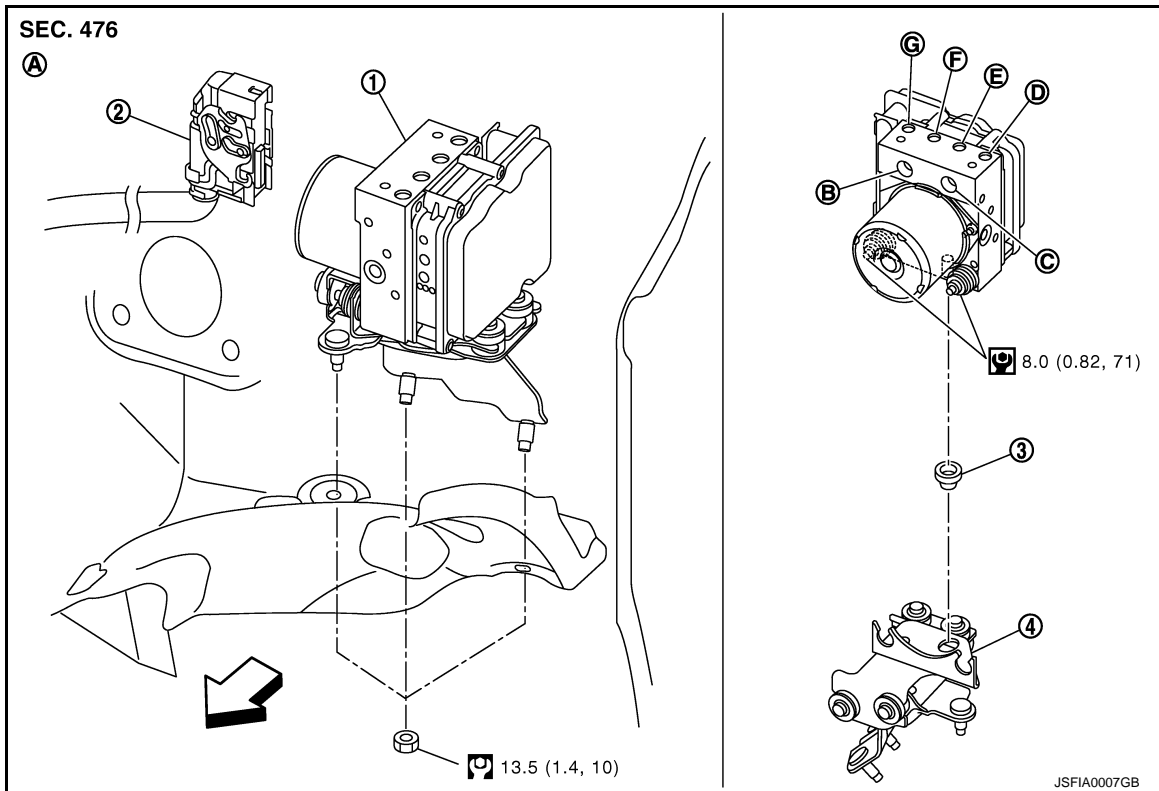

- | | | |
|--|--|--------------------------------------|
| 1. ABS actuator and electric unit (control unit) | 2. Connector | 3. Bushing |
| 4. Bracket | | |
| A. Left side of dash panel | B. From master cylinder secondary side | C. From master cylinder primary side |
| D. To front LH brake caliper | E. To rear RH brake caliper | F. To Rear LH brake caliper |
| G. To front RH brake caliper | | |

←: Vehicle front

Refer to [GI-4, "Components"](#) for symbol marks in the figure.

Removal and Installation

INFOID:000000006450617

REMOVAL

CAUTION:

- Before servicing, disconnect the battery cable from negative terminal.
- To remove brake tube, use a flare nut wrench to prevent flare nuts and brake tube from being damaged. To install, use flare nut crowfoot and torque wrench.
- Do not apply excessive impact to ABS actuator and electric unit (control unit), such as dropping it.
- Do not remove and install actuator by holding harness.
- After work is completed, bleed air from brake tube. Refer to [BR-11, "Bleeding Brake System"](#).

1. Remove cowl top cover. Refer to [EXT-23, "Exploded View"](#).
2. Disconnect ABS actuator and electric unit (control unit) connector.
3. Loosen brake tube flare nuts, then remove brake tubes from ABS actuator and electric unit (control unit).
4. Remove tire (front LH side).
5. Remove fender protector (rear): (front LH side). Refer to [EXT-26, "FENDER PROTECTOR : Exploded View"](#).
6. Remove ABS actuator and electric unit (control unit) bracket mounting nut.

ABS ACTUATOR AND ELECTRIC UNIT (CONTROL UNIT)

< REMOVAL AND INSTALLATION >

[VDC/TCS/ABS]

7. Remove ABS actuator and electric unit (control unit) from vehicle.

INSTALLATION

Note the following, and install in the reverse order of removal.

CAUTION:

- Before servicing, disconnect the battery cable from negative terminal.
- To remove brake tube, use a flare nut wrench to prevent flare nuts and brake tube from being damaged. To install, use flare nut crowfoot and torque wrench.
- Do not apply excessive impact to ABS actuator and electric unit (control unit), such as dropping it.
- Do not remove and install actuator by holding harness.
- After work is completed, bleed air from brake tube. Refer to [BR-11, "Bleeding Brake System"](#).
- After installing harness connector in the ABS actuator and electric unit (control unit), make sure connector is securely locked.
- When replacing ABS actuator and electric unit (control unit), make sure to adjust neutral position of steering angle sensor. Refer to [BRC-9, "ADJUSTMENT OF STEERING ANGLE SENSOR NEUTRAL POSITION : Description"](#).

A
B
C
D
E
G
H
I
J
K
L
M
N
O
P

BRC

YAW RATE/SIDE G SENSOR

< REMOVAL AND INSTALLATION >

[VDC/TCS/ABS]

YAW RATE/SIDE G SENSOR

Exploded View

INFOID:000000006450618

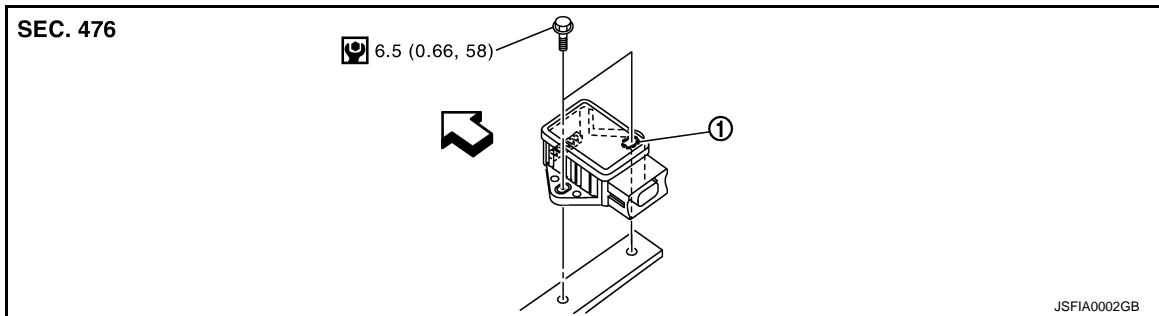

1. Yaw rate/side G sensor

↔: Vehicle front

Refer to [GI-4, "Components"](#) for symbol makes in the figure.

Removal and Installation

INFOID:000000006450619

REMOVAL

CAUTION:

- Do not drop or strike yaw rate/side G sensor, or do not use power tool etc., because yaw rate/side G sensor is sensitive to the impact.

1. Remove center console. Refer to [IP-34, "A/T MODELS : Exploded View"](#) (A/T models), [IP-39, "M/T MODELS : Exploded View"](#) (M/T models).
2. Disconnect yaw rate/side G sensor harness connector.
3. Remove mounting bolts. Remove yaw rate/side G sensor.

INSTALLATION

Note the following, and install in the reverse order of removal.

CAUTION:

- Do not drop or strike yaw rate/side G sensor, or do not use power tool etc., because yaw rate/side G sensor is sensitive to the impact.

STEERING ANGLE SENSOR

< REMOVAL AND INSTALLATION >

[VDC/TCS/ABS]

STEERING ANGLE SENSOR

Exploded View

INFOID:000000006450620

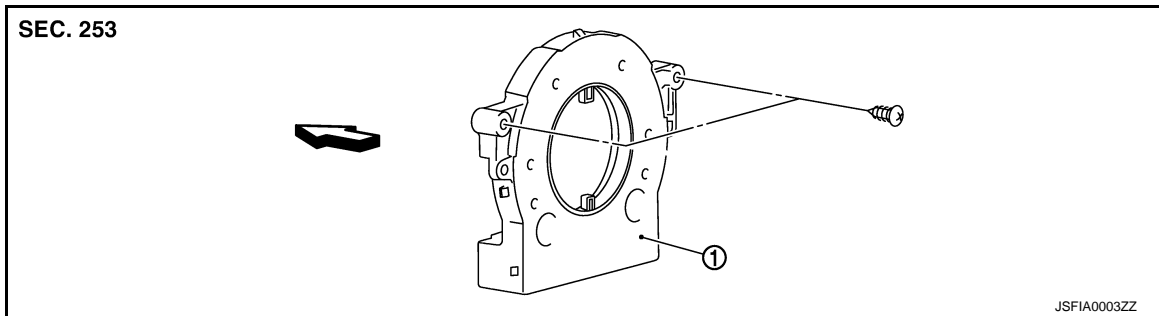

1. Steering angle sensor

↩: Vehicle front

Removal and Installation

INFOID:000000006450621

REMOVAL

1. Remove spiral cable assembly. Refer to [SR-14. "Exploded View"](#).
2. Remove steering angle sensor from spiral cable assembly.

INSTALLATION

Note the following, and install in the reverse order of removal.

CAUTION:

- After work, make sure to adjust neutral position of steering angle sensor. Refer to [BRC-9. "ADJUSTMENT OF STEERING ANGLE SENSOR NEUTRAL POSITION : Description"](#).
- Perform 4WAS front actuator adjustment. Refer to [STC-29. "4WAS FRONT ACTUATOR NEUTRAL POSITION ADJUSTMENT : Description"](#).

A
B
C
D
E
G
H
I
J
K
L
M
N
O
P

BRC

SYSTEM DESCRIPTION

PREVIEW FUNCTION

System Description

INFOID:000000006450622

FUNCTION DESCRIPTION

When the Preview Function identifies the need to apply emergency braking by sensing a vehicle ahead in the same lane and the distance and relative speed from it, it applies the brake pre-pressure before the driver depress the brake pedal and helps improve brake response by reducing pedal free play.

The Preview Function shares component parts and diagnosis with the ICC (Intelligent Cruise Control) system.

CAUTION:

This system is only an aid to assist braking operation and is not a collision warning or avoidance device. It is the driver's responsibility to stay alert, drive safely and be in control of the vehicle at all times.

OPERATION DESCRIPTION

Operation

- The system detects the distance to the vehicle in front with the ICC sensor integrated unit of ICC and judges the necessity of emergency braking.
- The system detects the accelerator pedal release operation of the driver by the accelerator pedal position sensor and estimates the driver's brake operation intention.
- If the system is judged that the emergency braking is necessary and that the driver has the intention to operate the brake, the ABS actuator and electric unit (control unit) applies pre-pressure to reduce brake pedal play.

NOTE:

This system will not operate when the vehicle is moving at approximately 32 km/h (20 MPH) or less.

End of Operation

The pre-pressure function ceases when the following conditions are met:

1. When the driver depresses the accelerator pedal or the brake pedal.
2. If the driver does not operate the accelerator pedal or brake pedal within approximately 1 second.

PREVIEW FUNCTION

[BRAKE ASSIST (WITH PREVIEW FUNCTION)]

< SYSTEM DESCRIPTION >

Component Parts Location

INFOID:000000006923806

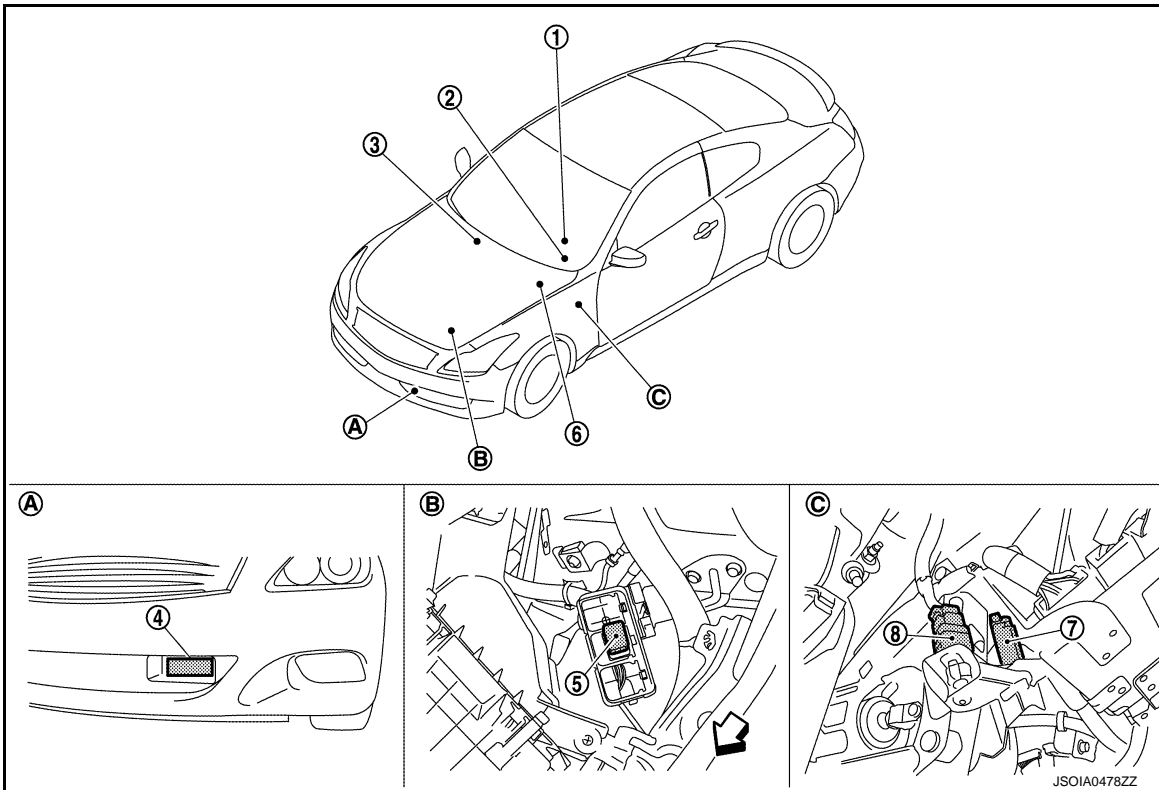

- | | | |
|---|-------------------------|---|
| 1. Information display, ICC system warning lamp, buzzer | 2. ICC steering switch | 3. ECM
Refer to EC-38, "Component Parts Location" |
| 4. ICC sensor integrated unit | 5. ICC brake hold relay | 6. ABS actuator and electric unit (control unit)
Refer to BRC-12, "Component Parts Location" |
| 7. ICC brake switch | 8. Stop lamp switch | |
| A. Front bumper (LH) | B. Engine room (LH) | C. Upper side of brake pedal |

Component Description

INFOID:000000006923807

×: Applicable

Component	Function Description			Description
	*1	*2	*3	
ICC sensor integrated unit	×	×	×	Refer to CCS-41, "Description" .
ECM	×	×	×	Refer to CCS-63, "Description" .
ABS actuator and electric unit (control unit)	×	×	×	Refer to CCS-47, "Description" .
BCM	×			Transmits the front wiper request signal to ICC sensor integrated unit via CAN communication.
TCM	×	×		Refer to CCS-88, "Description" .
Unified meter and A/C amp.	×	×	×	Receives the meter display signal, buzzer output signal, and ICC warning lamp signal from ICC sensor integrated unit via CAN communication and transmits them to the combination meter via the communication line.

PREVIEW FUNCTION

< SYSTEM DESCRIPTION >

[BRAKE ASSIST (WITH PREVIEW FUNCTION)]

Component	Function Description			Description
	*1	*2	*3	
Combination meter	×	×	×	Performs the following operations using the signals received from the unified meter and A/C amp. via the communication line. <ul style="list-style-type: none"> • Displays the ICC system operation status using the meter display signal. • Illuminates the ICC system warning lamp using the ICC warning lamp signal. • Operates the buzzer (ICC warning chime) using the buzzer output signal.
ICC brake switch	×	×	×	Refer to CCS-49. "Description" .
Stop lamp switch	×	×	×	
ICC brake hold relay	×		×	Refer to CCS-57. "Description" .

*1: Vehicle-to-vehicle distance control mode

*2: Conventional (fixed speed) cruise control mode

*3: Brake Assist (With Preview Function)

PREVIEW FUNCTION

< DTC/CIRCUIT DIAGNOSIS >

[BRAKE ASSIST (WITH PREVIEW FUNCTION)]

DTC/CIRCUIT DIAGNOSIS

PREVIEW FUNCTION

Diagnosis Procedure

INFOID:000000006450625

1. PREVIEW FUNCTION DIAGNOSIS

When the preview function is not operating properly, the buzzer sounds and the preview function warning lamp will come on.

NOTE:

The preview function warning lamp shares the ICC system warning lamp.

>> Go to ICC. Refer to [CCS-4, "Work Flow"](#).

A
B
C
D
E
G
H
I
J
K
L
M
N
O
P

BRC

NORMAL OPERATING CONDITION

< SYMPTOM DIAGNOSIS >

[BRAKE ASSIST (WITH PREVIEW FUNCTION)]

SYMPTOM DIAGNOSIS

NORMAL OPERATING CONDITION

Description

INFOID:000000006450626

PRECAUTIONS FOR PREVIEW FUNCTION

- This system is only an aid to assist braking operation and is not a collision warning or avoidance device. It is the driver's responsibility to stay alert, drive safely and be in control of the vehicle at all times.
- As there is a performance limit to the Preview Function, never rely solely on this system. This system does not correct careless inattentive or absent-minded driving, or overcome poor visibility in rain, fog, or other bad weather. Reduce vehicle speed by depressing the brake, in order to maintain a safe distance between vehicles.
- The system may not detect a vehicle ahead, depending on road or weather conditions. While the vehicle still travels and the Brake Assist System operates under normal conditions, the Preview Function may operate improperly under the following conditions:
 - When rain, snow or dirt adhere to the system sensor
 - When strong light (for example, at sunrise or sunset) is directly shining on the front of the vehicle
 - Winding or hilly roads may cause the sensor to temporarily not detect a vehicle in the same lane or may detect objects or vehicles in other lanes.
 - Vehicle position in the lane may cause the sensor to temporarily not detect a vehicle in the same lane or may detect objects or vehicles in other lanes.
- The system will not detect:
 - Pedestrians or objects in the roadway
 - Oncoming vehicles in the same lane
 - Motorcycles traveling offset in the travel lane as illustrated
- When the Preview Function operates, the brake pedal may move slightly and may make a small noise. This is not a system malfunction.

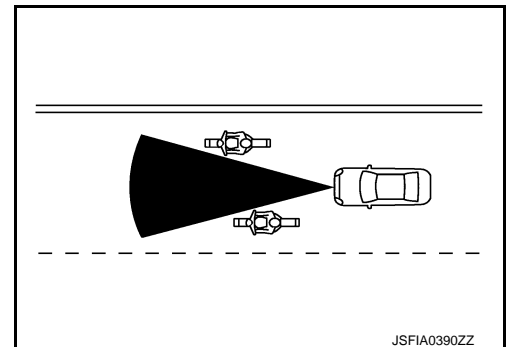

PRECAUTIONS

[BRAKE ASSIST (WITH PREVIEW FUNCTION)]

< PRECAUTION >

PRECAUTION

PRECAUTIONS

Precautions for Preview Function Service

INFOID:000000006450627

CAUTION:

- Never look straight into the laser beam discharger when adjusting laser beam aiming.
- Never use the ICC sensor integrated unit removed from vehicle. Never disassemble or remodel.

A
B
C
D
E
G
H
I
J
K
L
M
N
O
P

BRC